

Clevises with elongated hole

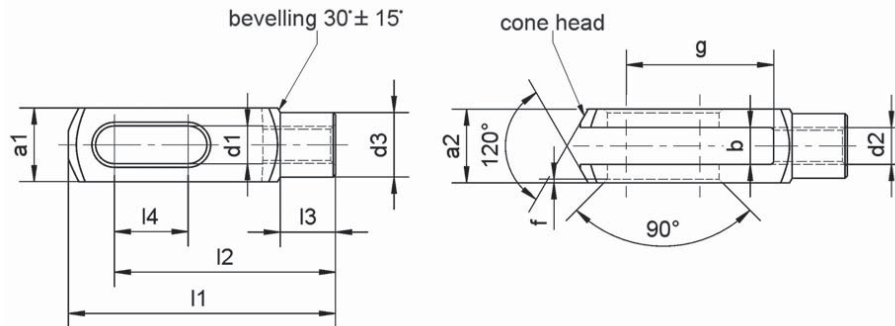

Example for ordering: Clevis with elongated hole, $d_1=10.2$ mm, slot length $g=40$ mm, with metric fine-pitch thread $d_2=M 10 \times 1.25$;
Clevis with elongated hole G 10×40 , M 10×1.25
Order number: 14 22 0010 0040



mbo standard 22

Size	Order number	d_1 $\pm 0,1$	$d_2^{1)}$		b $+0.7$ -0.1	$a_1^{2)}$ h11	a_2 $+0.5$ -0.2	l1 ± 0.5	l2 ± 0.4	l3 ± 0.2	d3 ± 0.2	g ± 0.5	f ± 0.2	l4 ± 0.4	Mass (kg) per piece
			Regular thread	Fine-pitch thread											
G 6x24	10 22 0006 0024	6.2	M 6x1		6	12	43	36	9	10	24	0.5	12	0.017	
G 8x32	10 22 0008 0032	8.2	M 8x1.25		8	16	58	48	12	14	32	0.5	16	0.043	
G 8x32	12 22 0008 0032	8.2		M 8x1	8	16	58	48	12	14	32	0.5	16	-	
G 10x40	10 22 0010 0040	10.2	M 10x1.5		10	20	72	60	15	18	40	0.5	20	0.086	
G 10x40	14 22 0010 0040	10.2		M 10x1.25	10	20	72	60	15	18	40	0.5	20	0.086	
G 12x48	10 22 0012 0048	12.2	M 12x1.75		12	24	86	72	18	20	48	0.5	24	0.141	
G 12x48	14 22 0012 0048	12.2		M 12x1.25	12	24	86	72	18	20	48	0.5	24	0.141	
G 14x56	10 22 0014 0056	14.2	M 14x2		14	27	101	85	22.5	24	56	1	28	-	
G 14x56	16 22 0014 0056	14.2		M 14x1.5	14	27	101	85	22.5	24	56	1	28	-	
G 16x64	10 22 0016 0064	16.2	M 16x2		16	32	115	96	24	26	64	1	32	-	
G 16x64	16 22 0016 0064	16.2		M 16x1.5	16	32	115	96	24	26	64	1	32	-	

¹⁾ code for thread:
regular thread
regular thread, left-handed
fine-pitch thread
fine-pitch thread, left-handed

no code
LH
FG
FGLH

²⁾ for semifinished products, tolerance h11 according to DIN 178

08_01
01/2007

Material:

1.0718 (11SMnPb30+C)

alternative: stainless steel 1.4305 (X8CrNiS18-9)



Surface protection:

polished oiled or at manufacturer's choice
optional: phosphatized and oiled,
electroplated galvanized, passivated in
white-blue (silver/clear) or yellow

Retaining:

with bolts (mbo catalog section 4 and 6) and
retainers (mbo catalog section 13) or washer and cotter pin;
also see clevis joint combinations
(mbo catalog section 11)

Special version:

left-handed and other threads or special slot
widths "b" and transversal hole upon request;
please send us your inquiry