

SL-3

1/4" "SUPER LIGHT" HEAVY DUTY RIVETER

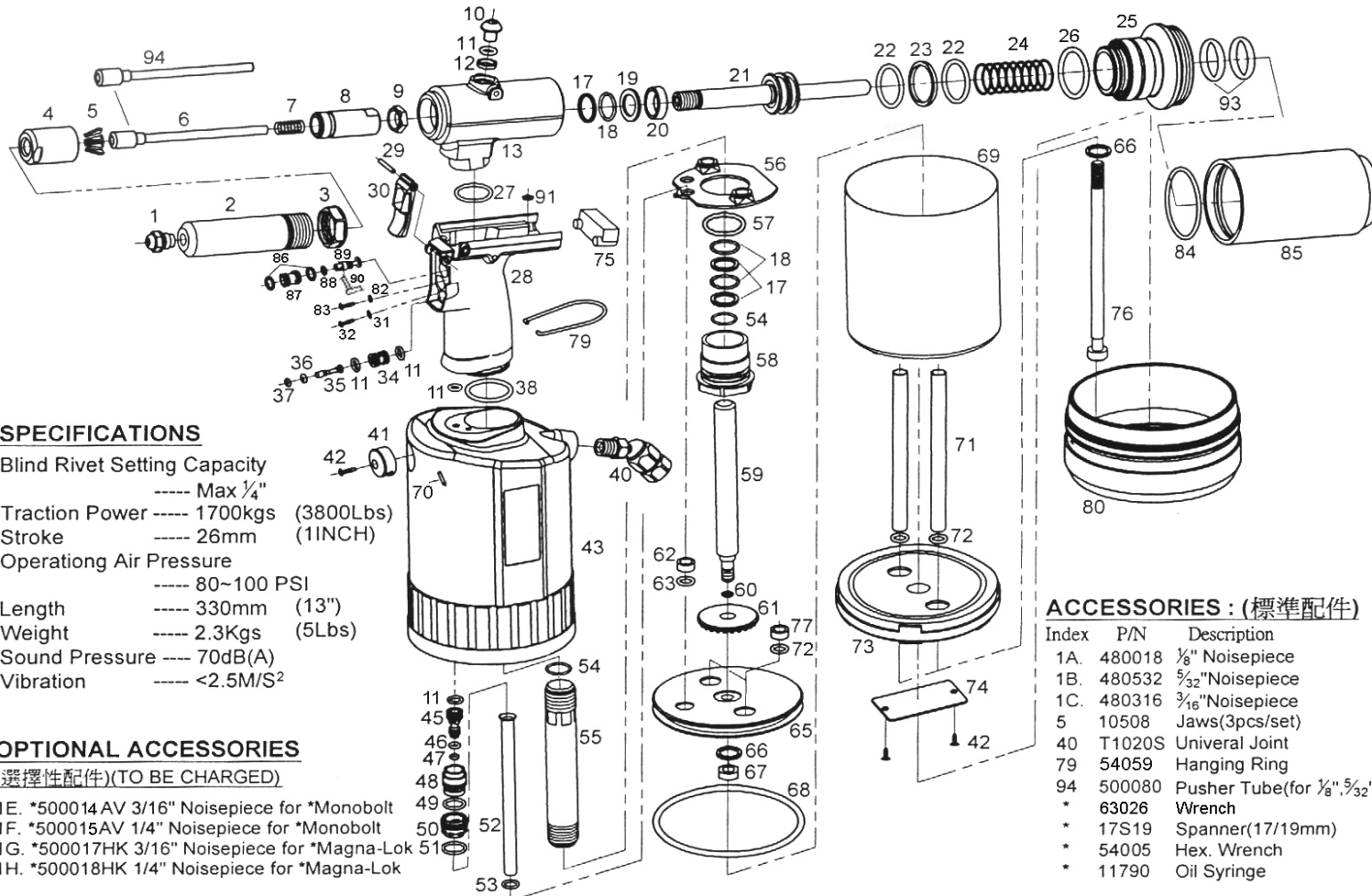

THE FUSION OF PRODUCTION
AND TECHNOLOGY™



SPECIFICATIONS

Blind Rivet Setting Capacity
----- Max 1/4"
Traction Power ----- 1700kgs (3800Lbs)
Stroke ----- 26mm (1INCH)
Operating Air Pressure
----- 80~100 PSI
Length ----- 330mm (13")
Weight ----- 2.3Kgs (5Lbs)
Sound Pressure ----- 70dB(A)
Vibration ----- <2.5M/S²

OPTIONAL ACCESSORIES

(選擇性配件)(TO BE CHARGED)

1E. *500014 AV 3/16" Noisepiece for *Monobolt
1F. *500015 AV 1/4" Noisepiece for *Monobolt
1G. *500017HK 3/16" Noisepiece for *Magna-Lok
1H. *500018HK 1/4" Noisepiece for *Magna-Lok

ACCESSORIES : (標準配件)

Index	P/N	Description
1A.	480018	1/8" Noisepiece
1B.	480532	5/32" Noisepiece
1C.	480316	3/16" Noisepiece
5	10508	Jaws(3pcs/set)
40	T1020S	Universal Joint
79	54059	Hanging Ring
94	500080	Pusher Tube(for 1/8", 5/32")
*	63026	Wrench
*	17S19	Spanner(17/19mm)
*	54005	Hex. Wrench
*	11790	Oil Syringe

107C

Index No.	Part No.	Description	Index No.	Part No.	Description	Index No.	Part No.	Description
1	500064	1/4" Nosepiece	35	63016V	Trigger Stem	69	680100	Cylinder Cup
2	68015V	Head	36	R2X15	O-Ring Seal	70	400031	Pin
3	600016	Nut	37	R1-9X19	O-Ring Seal	71	68094	Tube (2)
4	54009	Jaw Housing	38	630356	O-Ring Seal	72	R9-3X23	O-Ring Seal (4)
5	500008	Jaws(3pcs/set)	41	63031	O-Ring Seal	73	68004V	Cylinder Cap
6	500007A	Pusher Tube	42	25020	Screw (3)	74	63048	Name Plate
7	500005	Spring	43	68005	Air Cylinder Body	75	63060	Rubber Plug
8	68006	Jaw Housing Couple	45	63038	Throttle valve	76	680150	Bolt (2)
9	6801732	Nut	46	10512	O-Ring Seal	77	68095	Bush (2)
10	02171	Oil Plug	47	35016	O-Ring Seal	80	680106	Rubber cushion
11	02197	O-Ring Seal (5)	48	63037	Upper Bush	82	630W11X4	Washer
12	400017A	Fill washer	49	10445	O-Ring Seal	83	630BS3X6	Screw
13	68002V	Hydraulic Section	50	63036	Law Bush	84	P36X2	O-Ring Seal
17	11554	Washer (3)	51	25022	O-Ring Seal	85	500610C	Mandrel Bottle Ass'y
18	11502	X-Ring Seal (3)	52	64039	Valve Tube	86	R6-4X15	O-Ring Seal (2)
19	6801422	Washer	53	630RW8X2	Rubber Washer	87	63052	Valve Bush
20	FU011650	USI Ø14 x Ø22 x 5	54	R18X2	O-Ring Seal (2)	88	R4X1.5	O-Ring Seal
21	68051V	Hydraulic Plunger	55	63066	Valve pipe	89	63053	Valve Stem
22	11501	O-Ring Seal (2)	56	68032	Pipe Washer	90	63089	Lever
23	11549	Washer	57	R266X24	O-Ring Seal	91	64078	Rubber Washer
24	5002580	Hyd. Return Spring	58	68057	Screw Plug	93	31413	O-Ring Seal (2)
25	500070	Screw Plug	59	68022	Plunger Rod			
26	55019	O-Ring Seal	60	R5X15	O-Ring Seal			
27	R16X17	O-Ring	61	63030	Cushion			
28	63003V	Hydraulic Handle	62	63079	Bush			
29	25018B	Roll Pin	63	35039	O-Ring Seal			
30	63010	Trigger	65	68020	Piston			
31	630W3	Washer	66	48047	Washer (3)			
32	630M3	Screw	67	48048	Nut			
34	63009	Trigger Bush	68	R88X53	O-Ring Seal			

If Setting 1/8", 5/32" rivets, you must remove Pusher Tube #6(500007A) & Jaws #5(500008), Then replace with small pusher Tube #94(500080) & Jaws #5(10508)