

**HIGH SPEED STEEL / GROUND THREAD
49° QUICK SPIRAL FLUTED TAPS - METRIC
SERIES 920 : VERMONT TAP & DIE**



Size mm	Pitch mm	Pitch Dia. Limit	No. of Flutes	Order No.		Price
				Plug	Bott	
3.0	.50	D3	2	366110	366112	
3.5	.60	D4	3	366120	366122	
4.0	.70	D4	3	366130	366132	
5.0	.80	D4	3	366140	366142	
6.0	1.00	D5	3	366150	366152	
8.0	1.25	D5	3	366160	366162	
10.0	1.50	D6	3	366170	366172	
12.0	1.75	D6	3	366180	366182	

**HIGH SPEED STEEL / GROUND THREAD
THREAD FORMING
TAPS - FLUTELESS**



SERIES 557:



Size	TPI	Order No.	Price
2	56	5570256	
4	40	5570440	
5	40	5570540	
6	32	5570632	
8	32	5570832	
10	24	5571024	
10	32	5571032	
1/4	20	5571620	
1/4	28	5571628	
5/16	18	5572018	
5/16	24	5572024	
3/8	16	5572416	
3/8	24	5572424	
7/16	14	5572814	
7/16	20	5572820	
1/2	13	5573213	
1/2	20	5573220	

**HIGH SPEED STEEL / GROUND THREAD
S.T.I. (SCREW THREAD INSERT) TAPS
SERIES 935:**



Nominal Thread Size	Straight Flute					
	Plug Style (3B)			Bottoming Style (3B)		
	Model No.	Order No.	Price	Model No.	Order No.	Price
2-56	TP02-CPB	0110256		TP02-CBB	0120256	
3-48	TP03-CPB	0110348		TP03-CBB	0120348	
3-56	TP03-FPB	0110356		TP03-FBB	9120356	
4-40	TP04-CPB	0110440		TP04-CBB	0120440	
4-48	TP04-FPB	0110448		TP04-FBB	9120448	
5-40	TP05-CPB	0110540		TP05-CBB	0120540	
6-32	TP06-CPB	0110632		TP06-CBB	0120632	
6-40	TP06-FPB	0110640		TP06-FBB	0120640	
8-32	TP2-CPB	0110832		TP2-CBB	0120832	
8-36	TP2-FPB	0110836		TP2-FBB	0120836	
10-24	TP3-CPB	9011024		TP3-CBB	0121024	
10-32	TP3-FPB	9011032		TP3-FBB	0121032	
12-24	TP1-CPB	0111224		TP1-CBB	0121224	
12-28	TP1-FPB	9011228		TP1-FBB	0121228	
1/4-20	TP4-CPB	0111620		TP4-CBB	0121620	
1/4-28	TP4-FPB	0111628		TP4-FBB	9121628	
5/16-18	TP5-CPB	0112018		TP5-CBB	0122018	
5/16-24	TP5-FPB	0112024		TP5-FBB	0122024	
3/8-16	TP6-CPB	0112416		TP6-CBB	0122416	
3/8-24	TP6-FPB	0112424		TP6-FBB	0122424	
7/16-14	TP7-CPB	0112814		TP7-CBB	0122814	
7/16-20	TP7-FPB	0112820		TP7-FBB	0122820	
1/2-13	TP8-CPB	0113213		TP8-CBB	0123213	
1/2-20	TP8-FPB	0113220		TP8-FBB	0123220	
9/16-12	TP9-CPB	0113612		TP9-CBB	0123612	
9/16-18	TP9-FPB	0113618		TP9-FBB	0123618	
5/8-11	TP10-CPB	0114011		TP10-CBB	0124011	
5/8-18	TP10-FPB	0114018		TP10-FBB	0124018	
3/4-10	TP12-CPB	0114810		TP12-CBB	0124810	
3/4-16	TP12-FPB	0114816		TP12-FBB	9124816	
7/8-9	TP14-CPB	0115609		TP14-CBB	0125609	
7/8-14	TP14-FPB	0115614		TP14-FBB	0125614	
1-8	TP16-CPB	0116408		TP16-CBB	0126408	
1-12	TP161-FPB	0116412		TP161-FBB	0126412	
1-14	TP16-FPB	0116414		TP16-FBB	0126414	
1-1/8-7	TP18-CPB	0117207		TP18-CBB	0127207	
1-1/8-12	TP18-FPB	0117212		TP18-FBB	0127212	
1-1/4-7	TP20-CPB	0118007		TP20-CBB	0128007	
1-1/4-12	TP20-FPB	9018012		TP20-FBB	0128012	
1-3/8-6	TP22-CPB	0118806		TP22-CBB	0128806	
1-3/8-12	TP22-FPB	0118812		TP22-FBB	0128812	
1-1/2-6	TP24-CPB	9019606		TP24-CBB	0129606	
1-1/2-12	TP24-FPB	0119612		TP24-FBB	0129612	

Plug Style

4 Thread Chamfer-For thru holes and in blind holes that allow for ample chip clearance. Easier starting and requires less tapping torque than bottoming taps.



Bottoming Style

2 Thread Chamfer - For blind holes drilled to a minimum depth that requires threads close to the bottom of the hole.

**HIGH SPEED STEEL / GROUND THREAD
S.T.I. (SCREW THREAD INSERT) TAPS
SERIES 935:**



CUTTING TOOLS - TAPS & DIES

Nominal Thread Size	Spiral Point			Spiral Flute		
	Plug Style (3B)			Bottoming Style (3B)		
	Model No.	Order No.	Price	Model No.	Order No.	Price
2-56	TP02-CSB	0210256		TP02-CFB	0310256	
3-48	TP03-CSB	0210348		TP03-CFB	0310348	
4-40	TP04-CSB	0210440		TP04-CFB	0310440	
4-48	TP04-FSB	0210448		TP04-FFB	0310448	
5-40	TP05-CSB	0210540		TP05-CFB	0310540	
6-32	TP06-CSB	0210632		TP06-CFB	0310632	
6-40	TP06-FSB	0210640		TP06-FFB	0310640	
8-32	TP2-CSB	0210832		TP2-CFB	0310832	
8-36	TP2-FSB	0210836		TP2-FFB	0310836	
10-24	TP3-CSB	0211024		TP3-CFB	0311024	
10-32	TP3-FSB	0211032		TP3-FFB	0311032	
12-24	TP1-CSB	0211224		TP1-CFB	0311224	
1/4-20	TP4-CSB	0211620		TP4-CFB	0311620	
1/4-28	TP4-FSB	0211628		TP4-FFB	0311628	
5/16-18	TP5-CSB	0212018		TP5-CFB	0312018	
5/16-24	TP5-FSB	0212024		TP5-FFB	0312024	
3/8-16	TP6-CSB	0212416		TP6-CFB	0312416	
3/8-24	TP6-FSB	0212424		TP6-FFB	0312424	
7/16-14	TP7-CSB	0212814		TP7-CFB	0312814	
7/16-20	TP7-FSB	0212820		TP7-FFB	0312820	
1/2-13	TP8-CSB	0213213		TP8-CFB	0313213	
1/2-20	TP8-FSB	0213220		TP8-FFB	0313220	



Spiral Pointed Plug
4 Thread Chamfer - Incorporates an angular grind at the point end of the tap which shears chips and drives them forward of the tap. Used widely in long thru holes and blind holes with ample chip clearance. They are free cutting and provide increased tap strength. Not recommended for abrasive material.



High Spiral Flute - Bottoming
2 Thread Chamfer - Spiral flute for efficiently pulling stringy chips out of deep or blind holes in soft materials.

**HIGH SPEED STEEL / GROUND THREAD
S.T.I. (SCREW THREAD INSERT) TAPS - METRIC SIZES
SERIES 935:**



Nominal Thread Size	Straight Flute					
	Plug Style (5H)			Bottoming Style (5H)		
	Model No.	Order No.	Price	Model No.	Order No.	Price
M2.5 x .45	TP2.5M-CPA	0110204		TP2.5M-CBA	0120204	
M3 x .5	TP3M-CPA	0110305		TP3M-CBA	0120305	
M4 x .7	TP4M-CPA	9110407		TP4M-CBA	0120407	
M5 x .8	TP5M-CPA	0110508		TP5M-CBA	0120508	
M6 x 1.0	TP6M-CPA	0110610		TP6M-CBA	0120610	
M7 x 1.0	TP7M-CPA	0110710		TP7M-CBA	0120710	
M8 x 1.0	TP8M-FPA	0110810		TP8M-FBA	0120810	
M8 x 1.25	TP8M-CPA	0110812		TP8M-CBA	0120812	
M9 x 1.25	TP9M-CPA	0110912		TP9M-CBA	0120912	
M10 x 1.0	TP10M-FPA	0111010		TP10M-FBA	0121010	
M10 x 1.25	TP10M-MPA	0111012		TP10M-MBA	0121012	
M10 x 1.5	TP10M-CPA	0111015		TP10M-CBA	0121015	
M11 x 1.0	TP11M-FPA	0111110		TP11M-FBA	0121110	
M11 x 1.25	TP11M-MPA	9111112		TP11M-MBA	0121112	
M11 x 1.5	TP11M-CPA	9011115		TP11M-CBA	0121115	
M12 x 1.25	TP12M-FPA	0111212		TP12M-FBA	0121212	
M12 x 1.5	TP12M-MPA	0111215		TP12M-MBA	0121215	
M12 x 1.75	TP12M-CPA	0111217		TP12M-CBA	0121217	
M14 x 1.5	TP14M-FPA	0111415		TP14M-FBA	0121415	
M14 x 2.0	TP14M-CPA	9111420		TP14M-CBA	0121420	
M16 x 1.5	TP16M-FPA	0111615		TP16M-FBA	0121615	
M16 x 2.0	TP16M-CPA	9011620		TP16M-CBA	9021620	
M18 x 1.5	TP18M-FPA	0111815		TP18M-FBA	0121815	
M18 x 2.5	TP18M-CPA	0111825		TP18M-CBA	0121825	
M20 x 1.5	TP20M-FPA	0112015		TP20M-FBA	0122015	
M20 x 2.5	TP20M-CPA	0112025		TP20M-CBA	0122025	
M24x 3.0	TP24M-CPA	0112430		TP24M-CBA	0122430	



Plug Style
4 Thread Chamfer-For thru holes and in blind holes that allow for ample chip clearance. Easier starting and requires less tapping torque than bottoming taps.



Bottoming Style
2 Thread Chamfer - For blind holes drilled to a minimum depth that requires threads close to the bottom of the hole.

HIGH SPEED STEEL / GROUND THREAD

S.T.I. (SCREW THREAD INSERT) TAPS - METRIC SIZES

SERIES 935:



Nominal Thread Size	Spiral Point (5H)			High Spiral Flute (5H)		
	Model No.	Order No.	Price	Model No.	Order No.	Price
M2.5 x .45	TP2.5M-CSA	0210204		TP2.5M-CFA	0320204	
M3 x .5	TP3M-CSA	0210305		TP3M-CFA	0320305	
M4 x .7	TP4M-CSA	0210407		TP4M-CFA	0320407	
M5 x .8	TP5M-CSA	0210508		TP5M-CFA	0320508	
M6 x 1.0	TP6M-CSA	0210610		TP6M-CFA	0320610	
M8 x 1.0	TP8M-FSA	0210810		TP8M-FFA	0320810	
M8 x 1.25	TP8M-CSA	0210812		TP8M-CFA	0320812	
M10 x 1.0	TP10M-FSA	0211010		TP10M-FFA	0321010	
M10 x 1.25	TP10M-MSA	0211012		TP10M-MFA	0321012	
M10 x 1.5	TP10M-CSA	0211015		TP10M-CFA	0321015	
M12 x 1.25	TP12M-FSA	0211212		TP12M-FFA	0321212	
M12 x 1.5	TP12M-MSA	0211215		TP12M-MFA	0321215	
M12 x 1.75	TP12M-CSA	0211217		TP12M-CFA	0321217	



Spiral Pointed Plug

4 Thread Chamfer - Incorporates an angular grind at the point end of the tap which shears chips and drives them forward of the tap. Used widely in long thru holes and blind holes with ample chip clearance. They are free cutting and provide increased tap strength. Not recommended for abrasive material.



High Spiral Flute - Bottoming

2 Thread Chamfer - Spiral flute for efficiently pulling stringy chips out of deep or blind holes in soft materials.

HIGH SPEED STEEL /GROUND THREAD
DRILL / TAP COMBINATION

SERIES 324: STAR USA

SERIES 949: MEDA - SUPERIOR IMPORT

INCH SIZES



Size	Pitch	OAL	Thread Length	Drill Length	Drill Size	MEDA		STAR USA	
						Order No.	Price	Order No.	Price
4-40	H2	1-7/8	3/8	1/4	.0910	5780005		3240440	
4-48	H2	1-7/8	3/8	1/4	.0945	5780010		3240448	
5-40	H2	1-15/16	13/32	9/32	.1040	5780015		3240540	
5-44	H2	1-15/16	13/32	9/32	.1060	5780020		3240544	
6-32	H3	2	7/16	5/16	.1115	5780025		3240632	
6-40	H3	2	7/16	5/16	.1170	5780030		3240640	
8-32	H3	2-1/8	1/2	3/8	.1375	5780035		3240832	
8-36	H3	2-1/8	1/2	3/8	.1405	5780040		3240836	
10-24	H3	2-3/8	5/8	13/32	.1545	5780045		3241024	
10-32	H3	2-3/8	5/8	13/32	.1635	5780050		3241032	
12-24	H3	2-3/8	21/32	15/32	.1805	5780055		3241224	
12-28	H3	2-3/8	21/32	15/32	.1860	5780060		3241228	
1/4-20	H3	2-1/2	25/32	17/32	.2080	5780065		3241620	
1/4-28	H3	2-1/2	25/32	17/32	.2200	5780070		3241628	
5/16-18	H3	2-27/32	15/16	11/16	.2660	5780075		3242018	
5/16-24	H3	2-27/32	15/16	11/16	.2770	5780080		3242024	
3/8-16	H3	3-3/8	1-1/16	13/16	.3225	5780085		3242416	
3/8-24	H3	3-3/8	1-1/16	13/16	.3395	5780090		3242424	
7/16-14	H3	3-3/4	1-1/4	1	.3770	5780095		3242814	
7/16-20	H3	3-3/4	1-1/4	1	.3955	5780100		3242820	
1/2-13	H3	4-1/16	1-3/8	1-1/8	.4350	5780105		3243213	
1/2-20	H3	4-1/16	1-3/8	1-1/8	.4580	5780110		3243220	



Drills and Taps in a single pass. Point is self-centering and eliminates the need for center drilling or center punching.

Can be used on multi-spindle heads with reversing mechanisms in most materials. 2 Flutes, Taper pipe sizes available; please inquire.

METRIC SIZES

Size	Pitch Dia.	Overall Length Inches	Drill Length Inches	Drill Size Inches	Thread Length Inches	MEDA		STAR USA	
						Order No.	Price	Order No.	Price
M3 x0.5	D3	1-15/16	9/32	.1015	13/32	5782005		2403050	
M3.5 x 0.6	D4	2	5/16	.1180	7/16	5782010		2403560	
M4 x 0.7	D4	2-1/8	3/8	.1340	1/2	5782015		2404070	
M4.5 x 0.75	D4	2-3/8	13/32	.1520	5/8	5782020		2404575	
M5 x 0.8	D4	2-3/8	13/32	.1700	5/8	5782025		2405080	
M6 x 1	D5	2-1/2	17/32	.2030	25/32	5782030		2406010	
M7 x 1	D5	2-27/32	11/16	.2420	15/16	5782035		2407010	
M8 x 1.25	D5	2-27/32	11/16	.2735	15/16	9782040		2408012	
M10 x 1.5	D6	3-3/8	13/16	.3440	1-1/16	5782045		2410150	
M12 x 1.75	D6	4-1/16	1-1/8	.4140	1-3/8	5782150		2412175	

HIGH SPEED STEEL / GROUND THREAD

PIPE TAPS

SERIES 9: TAPER (N.P.T. STANDARD & GOLD (TIN) COATED & N.P.T.F.)
 SERIES 10: STRAIGHT (N.P.S. & N.P.S.F.)



Size	Threads Per Inch	No. Of Flutes	NPT		NPTF		NPT(Gold)		NPS		NPSF	
			Order No.	Price	Order No.	Price	Order No.	Price	Order No.	Price	Order No.	Price
1/16	27	4	1005004		1505004		1515004		1010004		-	
1/8	27	4	1005008		1505008		1515008		1010008		9030008	
1/4	18	4	1005016		1505016		1515016		1010016		1030016	
3/8	18	4	1005024		1505024		9515024		1010024		1030024	
1/2	14	4	1005032		1505032		1515032		1010032		1030032	
3/4	14	5	1005048		1505048		9515048		1010048		1030048	
1	11-1/2	5	1005064		1505064		1515064		1010064		1030064	
1-1/4	11-1/2	5	1005080		1505080		1515080		1010080		1030080	
1-1/2	11-1/2	7	1005096		1505096		1515096		1010096		1030096	
2	11-1/2	7	1005200		1505200		1515200		1010200		9030200	
2-1/2	8	8	1005232		1505232				9910232		1030232	
3	8	8	1005300		1505300				8010300		1030300	
3-1/2	8	8	1005332		-							
4	8	8	1005399		-							

HIGH SPEED STEEL / GROUND THREAD

TAPER PIPE TAPS

INTERRUPTED THREAD

SERIES 11: N.P.T. & N.P.T.F.



HIGH SPEED STEEL / GROUND THREAD

PIPE TAPS - BRITISH STANDARD

55° THREAD ANGLE

SERIES 943:



Size	Threads Per Inch	No. of Flutes	NPT		NPTF	
			Order No.	Price	Order No.	Price
1/16	27	4	1015004		1035004	
1/8	27	4	1015008		1035008	
1/4	18	4	1015016		1035016	
3/8	18	4	1015024		1035024	
1/2	14	4	1015032		1035032	
3/4	14	5	1015048		1035048	
1	11-1/2	5	1015064		1035064	
1-1/4	11-1/2	5	1015080		1035080	
1-1/2	11-1/2	7	1015096		1035096	
2	11-1/2	7	1015200		1035200	

Size	Threads Per Inch	Straight Pipe B.S.P.F.		Taper Pipe B.S.P.T.	
		Order No.	Price	Order No.	Price
1/8	28	9430008		9431008	
1/4	19	9430016		9431016	
3/8	19	9430024		9431024	
1/2	14	9430032		9431032	
5/8	14	9930040		9431040	
3/4	14	9430048		9431048	
7/8	14	9430056		9431056	
1	11	9430100		9431100	
1-1/4	11	9430116		9431116	
1-1/2	11	9430132		9431132	
1-3/4	11	9430148		9431148	
2	11	9430200		9431200	

HIGH SPEED STEEL / GROUND THREAD

TAPER PIPE TAPS

SERIES 797 : STAR USA (N.P.T.)
 SERIES 921 : VERMONT TAP & DIE
 (N.P.T. & N.P.T.F.)



CARBON STEEL

TAPER PIPE TAPS

SERIES 945: TAPER (N.P.T.)



Size	Threads Per Inch	No. of Flutes	STAR USA		Vermont Tap & Die		
			Order No.	Price	Order No.		Price
					NPT	NPTF	
1/16	27	4	7970004		385307	385323	
1/8	27	4	7970008		385364	385380	
1/4	18	4	7970016		385398	385413	
3/8	18	4	7970024		385422	385448	
1/2	14	4	7970032		385455	385471	
3/4	14	5	7970048		385489	385505	
1	11-1/2	5	7970064		385513	385539	
1-1/4	11-1/2	5	7970080		385547	385562	
1-1/2	11-1/2	7	7970096		385570	385596	
2	11-1/2	7	7970200		385604	385620	

Size	Threads Per inch	No. of Flutes	Order No.	Price
1/16	27	4	8450004	
1/8	27	4	9450008	
1/4	18	4	9450016	
3/8	18	4	9450024	
1/2	14	4	9450032	
3/4	14	5	9450048	
1	11-1/2	5	9450064	
1-1/4	11-1/2	5	9450080	
1-1/2	11-1/2	7	9450096	
2	11-1/2	7	9450200	
2-1/2	8	8	9450232	
3	8	8	9450300	
3-1/2	8	8	9450332	
4	8	8	9450399	

**HIGH SPEED STEEL / GROUND THREAD
STRAIGHT PIPE TAPS
SERIES 921: VERMONT TAP & DIE**



Size	T.P.I	No. of Flutes	Order No.		Price
			NPS	NPSF	
1/8	27	4	387113	387220	
1/4	18	4	387121	387238	
3/8	18	4	387139	387246	
1/2	14	4	387147	387253	
3/4	14	5	387154	387261	
1	11-1/2	5	387162	387279	

**HIGH SPEED STEEL / GROUND THREAD
TAPER PIPE TAPS - STANDARD & INTERRUPTED
GOLD (TIN) COATED
SERIES 921: VERMONT TAP & DIE**



Size	Threads Per Inch	No. Of Flutes	Standard			Interrupted	
			NPT	NPTF	Price	NPTF	Price
1/16	27	4	385328	385329			
1/8	27	4	385385	385386		385755	
1/4	18	4	385409	385410		385789	
3/8	18	4	385443	385444		385813	
1/2	14	4	385458	385477		385847	
3/4	14	5	385500	385501		385870	
1	11-1/2	5	385534	385536		385904	
1-1/4	11-1/2	5	385680	385685			
1-1/2	11-1/2	7	385681	385686			
2	11-1/2	7	385682	385687			

**HIGH SPEED STEEL / GROUND THREAD
TAPER PIPE TAPS - HIGH HOOK
STANDARD & SURFACE TREATED
SERIES 921: VERMONT TAP & DIE**



Vermont taper pipe taps with high hook are manufactured to meet the needs of tapping ductile materials such as aluminum, free machining stainless steel and mild steels, which characteristically produce long, stringy chips. These taps are also offered with surface treatment primarily to prevent galling while tapping ductile materials. Surface treated taps are not recommended for aluminum.

Size	T.P.I	No. of Flutes	Standard			Surface Treated		
			Order No.		Price	Order No.		Price
			NPT	NPTF		NPT	NPTF	
1/8	27	4	916206	916211		919700	919705	
1/4	18	4	916213	916216		919715	919725	
3/8	18	4	916218	916221		919735	919727	
1/2	14	4	916223	916226		919745	919750	
3/4	14	5	916228	916231		919765	919755	
1	11-1/2	5	916233	916236		-	-	

**HIGH SPEED STEEL / GROUND THREAD
TAPER PIPE TAPS
INTERRUPTED THREAD
SERIES 921: VERMONT TAP & DIE**



Size	T.P.I.	No. of Flutes	Order No.		Price
			NPT	NPTF	
1/8	27	4	385737	385752	
1/4	18	4	385760	385786	
3/8	18	4	385794	385810	
1/2	14	4	385828	385844	
3/4	14	5	385851	385877	
1	11-1/2	5	385885	385901	
1-1/4	11-1/2	5	385919	-	
1-1/2	11-1/2	7	385943	-	

**HIGH SPEED STEEL / GROUND THREAD
CNC LONG TAPER PIPE TAPS
OVERALL LENGTH: 6", STANDARD AND GOLD (TiN) COATED
SERIES 921: VERMONT TAP & DIE**



Size	Threads Per Inch	No. Of Flutes	Overall Length	Standard			Gold	
				NPT	NPTF	Price	NPTF	Price
1/8	27	4	3	384524	386008		386129	
1/4	18	4	3-1/2	384525	386024		386152	
3/8	18	4	3-3/4	384526	386040		386186	
1/2	14	4	4-3/8	384527	386065		386210	
3/4	14	5	4-5/8	384528	-		-	
1	11-1/2	5	5-1/4	384529	-		-	

**HIGH SPEED STEEL / GROUND THREAD
LONG TAPER PIPE TAPS - (NPT)
OVERALL LENGTHS:
6", 8" & 12"
SERIES 550:**



Size	Threads Per Inch	Overall Length							
		4"		6"		8"		12"	
		Order No.	Price	Order No.	Price	Order No.	Price	Order No.	Price
1/8	27	5504008		5506008		5508008		-	
1/4	18	5504016		5506016		5508016		5501216	
3/8	18			5506024		-		5501224	
1/2	14			5506032		-		5501232	
3/4	14			5506048		5508048		5501248	
1	11-1/2			5506064		5508064		5501264	



BURR-BIT
SERIES 189:



Taps and deburrs in one operation! Saves tool changes and machine cycles.

- Eliminates expensive secondary deburring.
- Deburrs the top of the tapped hole as the tap is being withdrawn from the workpiece.
- Cuts in reverse *only* for a smooth clean chamfer.
- Independent Burr-Bit spring pressure produces same-depth chamfer *every time*.
- Repeatable results for thousands of cycles!
- Easy to install. Simply slips over the tap.
- Easily resharpenable on radial relief grinding fixture.
- 120° included angle; 90° available.

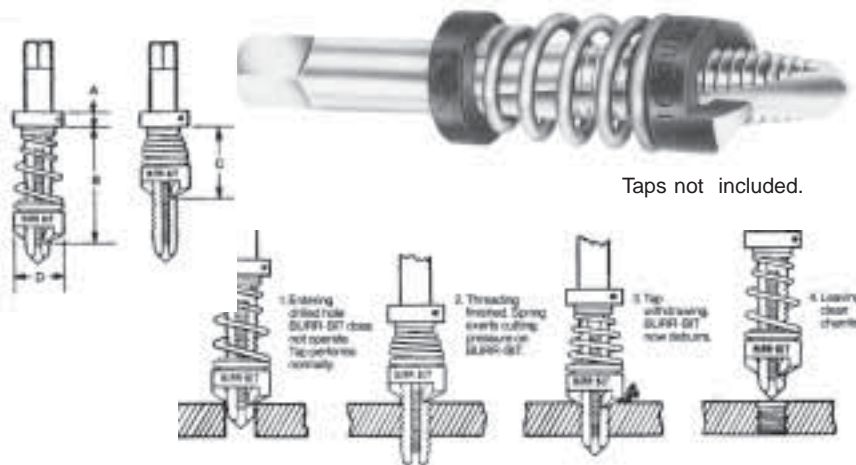

BURR-BITS FOR THREE FLUTE TAPS - INCH & METRIC

Tap Size	A (In)	B (In)	C (In)	D (In)	Order No. 120°	Price
#2-3FL	11/64	7/8	45/64	3/8	8902025	
#3-3FL	11/64	7/8	45/64	3/8	8902035	
#4-3FL	11/64	7/8	45/64	3/8	8902045	
#5-3FL	11/64	55/64	23/32	3/8	8902055	
#6-3FL	11/64	55/64	23/32	3/8	8902065	
#8-3FL	11/64	7/8	45/64	3/8	8902075	
#10-3FL	11/64	1-1/16	25/32	3/8	8902085	
#12-3FL	11/64	1-1/16	25/32	3/8	8902095	
1/4-3FL	11/64	1-9/64	7/8	1/2	8902115	
5/16-3FL	11/64	1-1/4	61/64	9/16	8902125	
3/8-3FL	11/64	1-1/4	61/64	21/32	8902135	
7/16-3FL	11/64	1-27/32	1-11/32	13/16	8902145	
1/2-3FL	11/64	1-47/64	1-15/64	13/16	8902155	
9/16-3FL	7/32	1-23/32	1-7/32	1	8902165	
5/8-3FL	7/32	1-57/64	1-19/64	1	8902175	
3/4-3FL	7/32	2-5/64	1-3/8	1-1/8	8902195	
M3-3FL	11/64	55/64	23/32	3/8	8903035	
M4-3FL	11/64	7/8	45/64	3/8	8903045	
M5-3FL	11/64	1-1/16	25/32	3/8	8903055	
M6-3FL	11/64	1-9/64	7/8	1/2	8903065	
M8-3FL	11/64	1-1/4	61/64	9/16	8903085	
M10-3FL	11/64	1-1/4	61/64	21/32	8903105	
M12-3FL	11/64	1-27/32	1-11/32	13/16	8903125	
M14-3FL	7/32	1-23/32	1-7/32	1	8903145	
M16-3FL	7/32	1-57/64	1-19/64	1	8903165	
M18-3FL	7/32	2	1	1-1/8	8903185	

BURR-BITS FOR TWO & FOUR FLUTE TAPS - INCH & METRIC

Tap Size	A (In)	B (In)	C (In)	D (In)	Order No. 120°	Price
#2-2FL	11/64	7/8	45/64	3/8	8902020	
#3-2FL	11/64	7/8	45/64	3/8	8902030	
#4-2FL	11/64	7/8	45/64	3/8	8902040	
#5-2FL	11/64	55/64	23/32	3/8	8902050	
#6-2FL	11/64	55/64	23/32	3/8	8902060	
#8-2FL	11/64	7/8	45/64	3/8	8902070	
#10-2FL	11/64	1-1/16	25/32	3/8	8902080	
#12-2FL	11/64	1-1/16	25/32	3/8	8902090	
1/4-2FL	11/64	1-9/64	7/8	1/2	8902110	
5/16-2FL	11/64	1-1/4	61/64	9/16	8902120	
3/8-2FL	11/64	1-1/4	61/64	21/32	8902130	
7/16-2FL	11/64	1-27/32	1-11/32	13/16	8902140	
1/2-2FL	11/64	1-47/64	1-15/64	13/16	8902150	
9/16-2FL	7/32	1-23/32	1-7/32	1	8902160	
5/8-2FL	7/32	1-57/64	1-19/64	1	8902170	
11/16-2FL	7/32	1-57/64	1-19/64	1-1/8	8902180	
3/4-2FL	7/32	2-5/64	1-3/8	1-1/8	8902190	
7/8-4FL	7/32	2-3/16	1-31/64	1-1/2	8902210	
1-4FL	7/32	2-5/8	1-25/32	1-1/2	8902230	
M3-2FL	11/64	55/64	23/32	3/8	8903030	
M4-2FL	11/64	7/8	45/64	3/8	8903040	
M5-2FL	11/64	1-1/16	25/32	3/8	8903050	
M6-2FL	11/64	1-9/64	7/8	1/2	8903060	
M8-2FL	11/64	1-1/4	61/64	9/16	8903080	
M10-2FL	11/64	1-1/4	61/64	21/32	8903100	
M12-2FL	11/64	1-27/32	1-11/32	13/16	8903120	
M14-2FL	7/32	1-23/32	1-7/32	1	8903140	
M16-2FL	7/32	1-57/64	1-19/64	1	8903160	
M18-2FL	7/32	2	1	1-1/8	8903180	
M20-2FL	7/32	2-3/16	1-31/64	1-1/2	8903200	
M22-2FL	7/32	2-13/64	1-7/16	1-1/2	8903220	
M24-2FL	7/32	2-13/64	1-7/16	1-1/2	8903240	



BURR-BIT
SERIES 189:

PIPE TAP BURR-BITS (NPT OR NPS)

Size	Collar ID(In)	O.D. (In)	Relaxed Lgth (In)	Compressed Lgth	Order No.	Price
1/8	.437	21/32	1-1/16	5/8	8904110	
1/4	.562	13/16	1-5/16	3/4	8904120	
3/8	.700	1-1/8	1-5/16	7/8	8904130	
1/2	NONE	1-1/2	1-1/2	7/8	8904140	
3/4	NONE	1-1/2	1-1/2	7/8	8904150	
1	NONE	1-7/8	1-7/8	1-7/8	8904160	

