

INDEXABLE THREADING & GROOVING TOOLHOLDERS

SERIES 915:



NS R/L THREADING & GROOVING TOOLHOLDER

External DorNotch Toolholder

for Threading and Grooving DorNotch Inserts

Description	Order Number		Price	A	B	C	D	E	F	Gage Insert	Seat	Seat Screw	Clamp	Clamp Screw
	RH	LH												
NSR/L06-2	6158770	6158771		0.375	0.375	2.5	.138	0.75	0.562					
NSR/L06-2D	6158772	6158773		0.375	0.375	6.0	.138	0.75	0.375					
NSR/L08-2J	6158774	6158775		0.500	0.500	3.5	.138	0.75	0.750					
NSR/L08-2D	6158776	6158777		0.500	0.500	6.0	.138	0.75	0.500	NG-2R*	-	-	CM-74*	S-310
NSR/L10-2B	6158778	6158779		0.625	0.625	4.5	.138	0.75	0.875	NG-2L*			CM-75*	
NSR/L10-2D	6158780	6158781		0.625	0.625	6.0	.138	0.75	0.875					
NSR/L12-2B	6158782	6158783		0.750	0.750	4.5	.138	0.75	1.000					
NSR/L16-2C	6158786	6158787		1.000	1.000	5.0	.138	0.75	1.250					
NSR/L12-3A	6158790	6158791		0.750	0.750	4.0	.210	1.25	1.000					
NSR/L12-3B	6158794	6158795		0.750	0.750	4.5	.210	1.25	1.000	NG-3R*	-	-	CM-72*	
NSR/L16-3C	6158798	6158799		1.000	1.000	5.0	.210	1.25	1.250	NG-3L*			CM-73*	S-412
NSR/L16-3D	6158802	6158803		1.000	1.000	6.0	.210	1.25	1.250					
NSR/L20-3D	6158806	6158807		1.250	1.250	6.0	.210	1.25	1.500					
NSR/L16-4C	6158810	6158811		1.000	1.000	5.0	.294	1.38	1.250					
NSR/L16-4D	6158814	6158815		1.000	1.000	6.0	.294	1.38	1.250	NG-4R*	SM-420	SL-344	CM-72*	S-412
NSR/L20-4C	6158818	6158819		1.250	1.250	5.0	.294	1.38	1.500	NG-4L*			CM-73*	
NSR/L20-4D	6158822	6158823		1.250	1.250	6.0	.294	1.38	1.500					
NSR/L24-4D	6158826	6158827		1.500	1.500	6.0	.294	1.38	1.750					

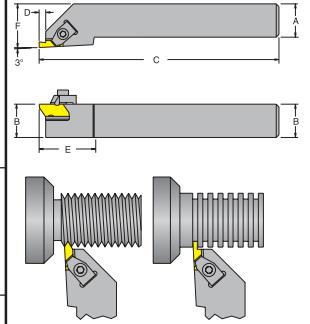

* For right hand tools * For left hand tools

NSR THREADING TOOLHOLDER SET

- DorNotch locking system
- For O.D. threading
- The insert nested in the holder is held extremely secure with a top clamp



Order No.	Price	Shank Size	Tool Lgth	TPI	12 pc. Set Includes		
					(1) Toolholder	(10) Inserts	(1) Storage Box
6185316		0.75	4.50	6-20	NSR12-3B	NT-3R-DC656	Storage Box
6185320		1.00	6.00	6-20	NSR16-3D	NT-3R-DC656	Storage Box

- Two cutting edges
- Clamp locking system
- General tooth form to handle a variety of sizes
- 60° "V" threading

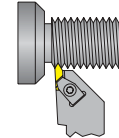

STVO R/L THREADING

TOOLHOLDERS

Style V - O.D. threading and shallow grooving for triangle TNMA inserts

Description	Order Number		Price	A	B	C	E	F	G	Max. Grv. Dpth V	Gage Insert	Insert Torx Screw
	RH	LH										
STVOR/L08-3A	6158070	6158071		0.500	0.500	4.0	1.00	0.625	.125	.150		
STVOR/L10-3B	6158074	6158075		0.625	0.625	4.5	1.00	0.750	.125	.150	322	GTS-1
STVOR/L12-3B	6158078	6158079		0.750	0.750	4.5	1.00	0.875	.125	.150		
STVOR/L16-3D	6158082	6158083		1.000	1.000	6.0	1.25	1.250	.250	.150		
STVOR/L12-4B	6158086	6158087		0.750	0.750	4.5	1.25	0.875	.125	.230		
STVOR/L16-4D	6158090	6158091		1.000	1.000	6.0	1.43	1.250	.250	.230	432	GTS-2
STVOR/L20-4D	6158094	6158095		1.250	1.250	6.0	1.25	1.500	.250	.230		
STVOR/L24-4E	6158098	6158099		1.500	1.500	7.0	1.25	1.750	.250	.230		
STVOR/L16-5D	6158102	6158103		1.000	1.000	6.0	1.50	1.250	.250	.292	543	GTS-3
STVOR/L20-5D	6158106	6158107		1.250	1.250	6.0	1.50	1.500	.250	.292		
STVOR/L20-64D	6158110	6158111		1.250	1.250	6.0	1.75	1.500	.250	.360	643	GTS-4
STVOR/L20-66D	6158114	6158115		1.250	1.250	6.0	1.75	1.500	.250	.360	663	GTS-4

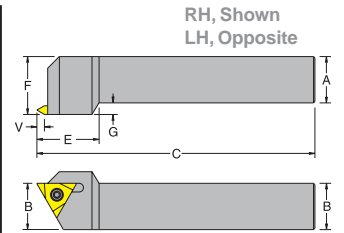

STVOR THREADING TOOLHOLDER SET

For O.D. threading and O.D. shallow grooving. Uses TNMC on edge inserts.



Order No.	Price	Shank Size	Tool Lgth	Max Dpth	13 pc. Set Includes		
					(1) Toolholder	(10) Inserts	(1) Torx Key
6185292		0.75	4.50	.150	STVOR12-3B	TNMC-32NV-DC656	T-10
6185296		1.00	6.00	.230	STVOR16-4D	TNMC-43NV-DC656	T-20

- Three cutting edges
- "C" style hole for torx screw locking system
- General tooth form to handle a variety of sizes
- 60° "V" threading

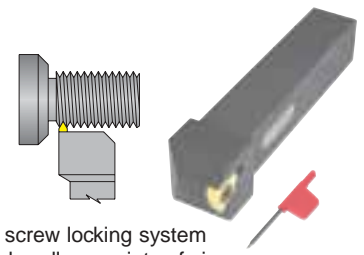

MTVO-A R/L THREADING

TOOLHOLDERS

SERIES 915:

Style V - O.D. threading and shallow grooving for triangle TNMA inserts

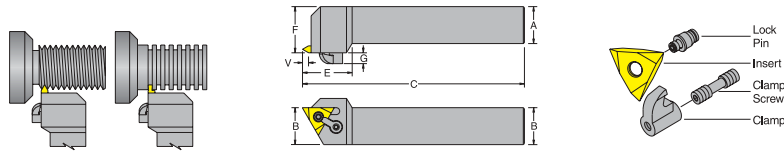

Description	Order No.		Price	A	B	C	E	F	G	Max. Grv. Dpth V	Gage Insert	Lock Pin	Clamp	Lock Screw
	RH	LH												
MTVOR/L08-3A-A	6158122	6158123		0.500	0.500	4.0	1.020	0.625	.250	.150	322	NL-33		XNS-35
MTVOR/L08-3B-A	6158126	6158127		0.500	0.500	4.5	1.020	0.625	.250	.150				
MTVOR/L10-3B-A	6158130	6158131		0.625	0.625	4.5	1.020	0.750	.250	.150				
MTVOR/L12-3B-A	6158134	6158135		0.750	0.750	4.5	1.020	0.875	.250	.150	322	NL-33		
MTVOR/L16-3D-A	6158138	6158139		1.000	1.000	6.0	1.155	1.250	.250	.150				
MTVOR/L12-4B-A	6158142	6158143		0.750	0.750	4.5	1.250	0.875	.250	.230			CL-6	XNS-36
MTVOR/L16-4D-A	6158146	6158147		1.000	1.000	6.0	1.250	1.250	.250	.230	432	NL-44		
MTVOR/L20-4D-A	6158150	6158151		1.250	1.250	6.0	1.250	1.500	.250	.230				
MTVOR/L24-4E-A	6158154	6158155		1.500	1.500	7.0	1.250	1.750	.250	.230				
MTVOR/L16-5D-A	6158158	6158159		1.000	1.000	6.0	1.500	1.250	.250	.292	543	NL-56		
MTVOR/L20-5D-A	6158162	6158163		1.250	1.250	6.0	1.500	1.500	.250	.292				
MTVOR/L20-64D-A	6618166	6158167		1.250	1.250	6.0	1.750	1.500	.316	.360	643	NL-66	CL-12	XNS-59
MTVOR/L20-66D-A	6158170	6158171		1.250	1.250	6.0	1.750	1.500	.316	.360	663	NL-66L		

MTVOR THREADING TOOLHOLDER SET

SERIES 915:

For O.D. threading and O.D. shallow grooving. Top clamp to allow threading closer to a shoulder. Side clamp to hold the insert with maximum rigidity.

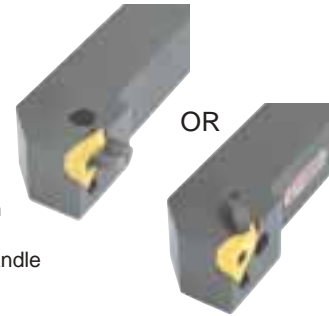
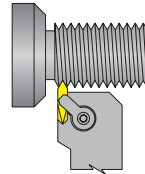

Order No.	Price	Shank Size	Tool Lgth.	Max Dpth	12 pc. Set Includes		(1)
					(1) Toolholder	(10) Inserts	
6185304		1.00	6.00	.230	MTVOR16-4D-AM	TNMA-43NV-DC656	Storage Box

- Three cutting edges
- "A" style hole for lock pin locking system
- General tooth form to handle a variety of sizes
- 60° "V" threading

S-NE R/L THREADING & GROOVING BORING BAR

SERIES 915:

Internal DorNotch Boring Bar for Threading and Grooving DorNotch Inserts

Description	Order Number		Price	Min. Bore B	C	D	F	Gage Insert	Clamp	Clamp Screw
	RH	LH								
S10S-NER/L-2	6158970	6158971		1.000	10.0	0.625	0.500	NG-2L*	CM-75*	S-310
S12S-NER/L-2	6158974	6158975		1.125	10.0	0.750	0.562	NG-2R*	CM-74*	
S16T-NER/L-3	6158978	6158979		1.375	12.0	1.000	0.688			
S20U-NER/L-3	6158982	6158983		1.750	14.0	1.250	0.875	NG-3L*	CM-73*	S-412
S24U-NER/L-3	6158986	6158987		2.000	14.0	1.500	1.000	NG-3R*	CM-72*	
S28U-NER/L-3	6158990	6158991		2.250	14.0	1.750	1.125			
S28U-NER/L-4	6158994	6158995		2.500	14.0	1.750	1.250	NG-4L*	CM-73*	S-412
S32V-NER/L-4	6158998	6158999		2.750	16.0	2.000	1.375	NG-4R*	CM-72*	

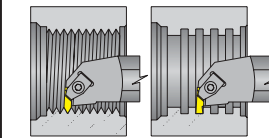
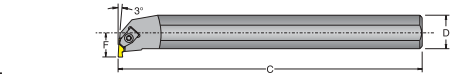

RH-Shown, LH-Opposite. RH tool uses LH insert.

NER THREADING BAR SET

SERIES 915:

- DorNotch locking system
- For I.D. threading
- The insert nested in the holder is held extremely secure with a top clamp

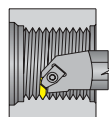

Order No.	Price	Shank Size	Min. Bore	TPI	12 pc. Set Includes		(1)
					(1) Boring Bar	(10) Inserts	
6185284		0.75	1.125	7-20	S12S-NER-2	NT-2L-DC656	Storage Box
6185288		1.00	1.375	5-12	S16T-NER-3	NT-3L-DC656	

- Two cutting edges
- Clamp locking system
- Compact insert allows for threading smaller bores
- General tooth form to handle a variety of sizes
- 60° "V" threading

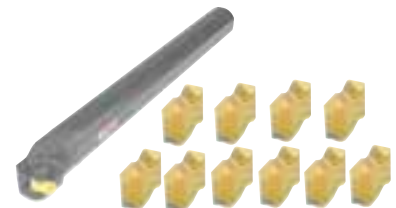

INSERT GRADE SELECTION

P25C For treated and hard Alloy Steels (25HRC & up) at medium to low cutting speeds.

MXC Coated Micrograin, for Free Cutting untreated Alloy Steels (Below 30HRC). For Stainless Steels and Cast Iron.

BXC For low cutting speed. Works well with wide range of Stainless Steels.



Materials	Coated Grades		
	MXC	P25C	BXC
Low & Medium Carbon Steels	100-250 330-830	100-200 330-660	20-100 70-330
High Carbon Steels	80-180 260-590	80-160 260-530	30-80 100-260
Alloy Steels Treated Steels	90-120 300-390	50-120 160-400	40-90 130-300
Stainless Steels	90-160 300-520		30-90 100-300
Cast Steels	130-170 430-560	90-150 300-500	40-90 130-300
Cast Iron	70-150 230-500		40-90 130-300
Non Ferrous & Aluminium	150-300 490-980		20-120 70-400

THREAD TURNING SPEED SELECTION

After selecting a suitable grade, please refer to the speed selection chart to select a recommended cutting speed. Top number is Meters/Min, bottom number is Feet/Min.

PARTIAL PROFILES 60°

L mm	I.C. inch	Pitch Range		EXTERNAL Right Hand*				INTERNAL Right Hand*			
		mm	TPI	Model No.	Order No. P25C	Order No. MXC	Price	Model No.	Order No. P25C	Order No. MXC	Price
11	1/4	0.5-1.5	48-16	11 ER A60	1110150	9110151		11 IR A60	9120150	9120151	
		0.5-1.5	48-16	16 ER A60	1610150	9610151		16 IR A60	9620150	9920151	
16	3/8	1.75-3.0	14-8	16 ER G60	1610100	9610161		16 IR G60	9620160	9620161	
		0.5-3.0	48-8	16 ER AG60	1610170	9610171		16 IR AG60	9620170	9620171	
22	1/2	3.5-5.0	7-5	22 ER N60	2210180	2210181		22 IR N60	2220180	2220181	
27	5/8	5.5-6.0	4.5-4	27 ER Q60	2710190	2710191		27 IR Q 60	2720190	2720191	

* Left Hand available; please inquire.



PARTIAL PROFILES 60°

INTERNAL, RIGHT HAND
ULTRA MINIATURE AND MINIATURE THREADING

L mm	I.C. inch	Pitch Range Model		Order No.	BXC	Price
		mm	TPI			
6	5/32	0.5-1.25	48-20	061RA60	0620152	
8	3/16	0.5-1.5	48-16	081RA60	0820152	

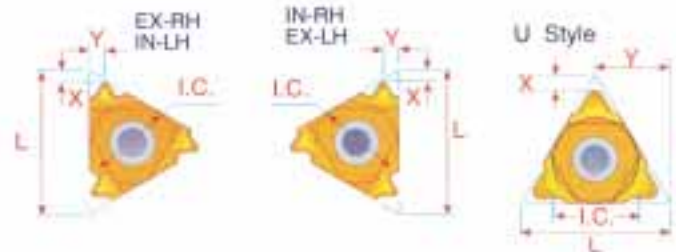

NPT

Pitch TPI	L mm	I.C. inch	External Right Hand				Internal Right Hand			
			Model No.	Order No. P25C	Order No. MXC	Price	Model No.	Order No. P25C	Order No. MXC	Price
27 18 14	11	1/4	11 ER 27 NPT	9110270	9110271		11 IR 27 NPT	9120270	9120271	
			11 ER 18 NPT	1110180	9110181		11 IR 18 NPT	9120180	9120181	
			11 ER 14 NPT	1110140	9110141		11 IR 14 NPT	9120140	9120141	
27 18 14 11.5 8	16	3/8	16 ER 27 NPT	1610270	9610271		16 IR 27 NPT	9620270	9620271	
			16 ER 18 NPT	1610180	9610181		16 IR 18 NPT	9620180	9620181	
			16 ER 14 NPT	1610140	9610141		16 IR 14 NPT	9620140	9620141	
			16 ER 11.5 NPT	1610110	9610111		16 IR 11.5 NPT	9620110	9620111	
			16 ER 8 NPT	1610080	9610081		16 IR 8 NPT	9620080	9620081	



NPT - INTERNAL, RIGHT HAND

ULTRA MINIATURE AND MINIATURE THREADING

Pitch TPI	L mm	I.C. inch	External Right Hand		
			Model No.	Order No. BXC	Price
27	6	5/32	061R27NPT	0620272	
27	8	3/16	081R27NPT	0820271	
18	8	3/16	081R18NPT	0820181	





ISO (Metric)

Pitch mm	L mm	I.C. in	EXTERNAL RIGHT HAND*				INTERNAL RIGHTHAND*			
			Model No.	Order No. P25C	Order No. MXC	Price	Model No.	Order No P25C	Order No. MXC	Price
0.5	11	1/4	11 ER 0.5 ISO	9110051	1110051		11 IR 0.5 ISO	1200501	1120051	
0.75	11	1/4	11 ER 0.75 ISO	1110070	1110071		11 IR 0.75 ISO	1120070	1120071	
0.8	11	1/4	11 ER 0.8 ISO	9110080	1101011		11 IR 0.8 ISO	1200809	1120081	
1.0	11	1/4	11 ER 1.0 ISO	1110100	1010111		11 IR 1.0 ISO	1120100	1120101	
1.25	11	1/4	11 ER 1.25 ISO	1110120	1110121		11 IR 1.25 ISO	1120120	1120121	
1.50	11	1/4	11 ER 1.5 ISO	9110150	1110151		11 IR 1.5 ISO	1120150	1120151	
1.75	11	1/4	11 ER 1.75 ISO	1110170	1110171		11 IR 1.75 ISO	1120170	1120171	
2.0	11	1/4	-	-	-		11 IR 2.0 ISO	1120200	9120200	
0.5	16	3/8	16 ER 0.5 ISO	1610050	1610051		16 IR 0.5 ISO	1620050	1620051	
0.75	16	3/8	16 ER 0.75 ISO	1610070	1610071		16 IR 0.75 ISO	1620070	1620071	
0.8	16	3/8	16 ER 0.8 ISO	9610080	1610081		16 IR 0.8 ISO	9990080	9920081	
1.0	16	3/8	16 ER 1.0 ISO	9610100	1610101		16 IR 1.0 ISO	1620100	9920101	
1.25	16	3/8	16 ER 1.25 ISO	9610120	1610121		16 IR 1.25 ISO	1620120	1620121	
1.5	16	3/8	16 ER 1.5 ISO	9610150	1610151		16 IR 1.5 ISO	1620150	1620151	
1.75	16	3/8	16 ER 1.75 ISO	9610170	1610171		16 IR 1.75 ISO	1620170	1620171	
2.0	16	3/8	16 ER 2.0 ISO	9610200	1610201		16 IR 2.0 ISO	9620200	1620201	
2.5	16	3/8	16 ER 2.5 ISO	1610250	1610251		16 IR 2.5 ISO	1620250	1620251	
3.0	16	3/8	16 ER 3.0 ISO	1610300	1610301		16 IR 3.0 ISO	9220300	1620301	
3.5	22	1/2	22 ER 3.5 ISO	2210350	2210351		22 IR 3.5 ISO	1620350	2220351	
4.0	22	1/2	22 ER 4.0 ISO	2210400	2210401		22 IR 4.0 ISO	2220400	2220401	
4.5	22	1/2	22 ER 4.5 ISO	2210450	2210451		22 IR 4.5 ISO	2220450	2220451	
5.0	22	1/2	22 ER 5.0 ISO	2210500	2210501		22 IR 5.0 ISO	2220500	2220501	
5.5	27	5/8	27 ER 5.5 ISO	2710550	2710551		27 IR 5.5 ISO	2720550	2720551	
6.0	27	5/8	27 ER 6.0 ISO	2710600	2710601		27 IR 6.0 ISO	2720600	2720601	

ISO (Metric) -
INTERNAL, RIGHT HAND ULTRA
MINIATURE AND MINIATURE
THREADING

Pitch mm	L mm	I.C. Inch	Model No.	Order No.	Price
0.5	6	5/32	061R0.5ISO	0620052	
0.75	6	5/32	061R0.75ISO	0620072	
1.0	6	5/32	061R1.0ISO	0620102	
1.25	6	5/32	061R1.25ISO	0620122	
0.5	8	3/16	081R0.5ISO	0820052	
0.75	8	3/16	081R0.75ISO	0820072	
1.0	8	3/16	081R1.0ISO	0820102	
1.25	8	3/16	081R1.25ISO	0820122	
1.5	8	3/16	081R1.5ISO	0920152	
1.75	8	3/16	081R1.75ISO	9820172	

* Left Hand available; please inquire.

UN (UNIFIED) UNC / UNF / UNEF / UNS

Pitch TPI	L mm	I.C. in	EXTERNAL Right Hand*				INTERNAL Right Hand*			
			Model No.	Order No. P25C	Order No. MXC	Price	Model No.	Order No P25C	Order No. MXC	Price
40	11	1/4	11 ER 40 UN	1110400	9110401		11 IR 40 UN	1120400	1120401	
36	11	1/4	11 ER 36 UN	1110360	1110361		11 IR 36 UN	1120360	1120361	
32	11	1/4	11 ER 32 UN	1110320	1110321		11 IR 32 UN	1120320	1120321	
28	11	1/4	11 ER 28 UN	1110280	1110281		11 IR 28 UN	1120280	1120281	
27	11	1/4	11 ER 27 UN	1110270	1110271		11 IR 27 UN	1120270	1120271	
24	11	1/4	11 ER 24 UN	1110240	1110241		11 IR 24 UN	1120240	1120241	
20	11	1/4	11 ER 20 UN	1110200	1110201		11 IR 20 UN	9920200	1120201	
18	11	1/4	11 ER 18 UN	9110180	1110181		11 IR 18 UN	1120180	1120181	
16	11	1/4	11 ER 16 UN	1110160	1110161		11 IR 16 UN	1120160	1120161	
14	11	1/4	11 ER 14 UN	9110140	1110141		11 IR 14 UN	1120140	1120141	
13	11	1/4	-	-	-		11 IR 13 UN	1120130	1120131	
12	11	1/4	-	-	-		11 IR 12 UN	9120120	9120121	
11	11	1/4	-	-	-		11 IR 11 UN	1120110	1120111	
40	16	3/8	16 ER 40 UN	1610400	1610401		16 IR 40 UN	1620400	1620401	
36	16	3/8	16 ER 36 UN	1610360	1610361		16 IR 36 UN	1620360	1620361	
32	16	3/8	16 ER 32 UN	1610320	1610321		16 IR 32 UN	1620320	1620321	
28	16	3/8	16 ER 28 UN	1610280	1610281		16 IR 28 UN	1620280	1620281	
27	16	3/8	16 ER 27 UN	9610270	1610271		16 IR 27 UN	1620270	1620271	
24	16	3/8	16 ER 24 UN	1610240	1610241		16 IR 24 UN	1622240	1622241	
20	16	3/8	16 ER 20 UN	1610200	9610201		16 IR 20 UN	9990200	9920201	
18	16	3/8	16 ER 18 UN	9610180	1610181		16 IR 18 UN	1620180	1620181	
16	16	3/8	16 ER 16 UN	1610160	1610161		16 IR 16 UN	1620160	1620161	
14	16	3/8	16 ER 14 UN	9610140	1610141		16 IR 14 UN	1620140	1620141	
13	16	3/8	16 ER 13 UN	1610130	1610131		16 IR 13 UN	1620130	1620131	
12	16	3/8	16 ER 12 UN	1610120	9910121		16 IR 12 UN	9620120	9620121	
11.5	16	3/8	16 ER 11.5 UN	1611150	1611151		16 IR 11.5 UN	1621150	1621151	
11	16	3/8	16 ER 11 UN	9910110	1610111		16 IR 11 UN	9921150	1620111	
10	16	3/8	16 ER 10 UN	9900100	1620101		16 IR 10 UN	3620110	9620101	
9	16	3/8	16 ER 9 UN	1610090	1620091		16 IR 9 UN	1620090	9620091	
8	16	3/8	16 ER 8 UN	6100801	1620081		16 IR 8 UN	6200801	9990081	
7	22	1/2	22 ER 7 UN	2210070	2220071		22 IR 7 UN	2220070	9220071	
6	22	1/2	22 ER 6 UN	2210060	2220061		22 IR 6 UN	2220060	9220061	
5	22	1/2	22 ER 5 UN	2210050	2220051		22 IR 5 UN	2220050	9220051	
4.5	27	5/8	27 ER 4.5 UN	2710450	2720451		27 IR 4.5 UN	2720450	9720451	
4	27	5/8	27 ER 4 UN	2710040	2720041		27 IR 4 UN	2720040	9720041	

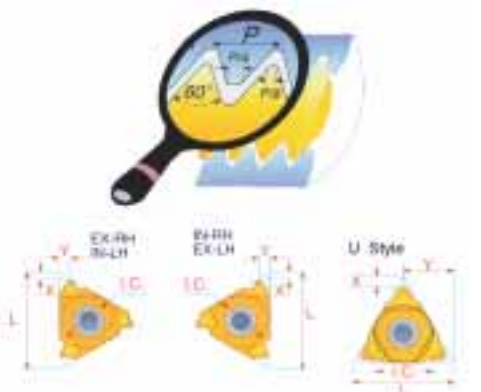

UN (UNIFIED) -
INTERNAL, RIGHT HAND
ULTRA MINIATURE AND
MINIATURE THREADING

Pitch TPI	L mm	I.C. inch	Model No. BXC	Order No.	Price
32	6	5/32	061R32UN	0620322	
28	6	5/32	061R28UN	0620282	
24	6	5/32	061R24UN	9620242	
20	6	5/32	061R20UN	0620202	
18	6	5/32	061R18UN	9620182	
32	8	3/16	081R32UN	0820332	
28	8	3/16	081R28UN	0820282	
24	8	3/16	081R24UN	0820242	
20	8	3/16	081R20UN	0820202	
18	8	3/16	081R18UN	9920182	
16	8	3/16	081R16UN	9820162	
14	8	3/16	081R14UN	0820142	

CUTTING TOOLS - INDEXABLE

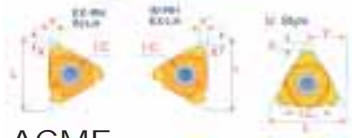

ACME

Pitch TPI	L mm	I.C. in	External Right Hand*				Internal Right Hand			
			Model No.	Order No. P25C	Order No. MXC	Price	Model No.	Order No. P25C	Order No. MXC	Price
16	11	1/4	11ER16 ACME	9110160	9110161		-	-	-	
16	16	3/8	16ER 16 ACME	9610160	9910161		-	-	-	
14	16	3/8	16ER 14 ACME	9990140	9910141		16 IR 14 ACME	9920140	9920141	
12	16	3/8	16ER 12 ACME	9990120	9610121		16 IR 12 ACME	9920120	9920121	
10	16	3/8	16ER 10 ACME	9990100	9610101		16 IR 10 ACME	1620110	9620111	
8	16	3/8	16ER 8 ACME	6100811	9910081		16 IR 8 ACME	2008016	6200811	
6	22	1/2	22 ER 6 ACME	9210060	2210061		22 IR 6 ACME	9220060	9920061	
5	22	1/2	22 ER 5 ACME	2100501	2210051		22 IR 5 ACME	9220050	9920051	
4	27	5/8	27 ER 4 ACME	9710040	2710041		27 IR 4 ACME	9720040	9920041	

ACME INTERNAL, RIGHT HAND MINIATURE THREADING

Pitch TPI	L mm	I.C. Inch	Model No.	Order No.	Price
16	8	3/16	08IR16 ACME*	0820162	

* One Cutting Edge

* One Cutting Edge

EXTERNAL TOOLHOLDERS, RIGHT HAND

LEFT HAND AND METRIC TOOLHOLDERS AVAILABLE; PLEASE INQUIRE

Model No.	Insert IC.	B = H Inch	L Inch	F Inch	Order No.	Price
*SER 0310 H11	1/4	0.31	4.00	0.43	1610310	
*SER 0375 H11	1/4	0.38	4.00	0.43	1610375	
SER 0375 D16	1/4	0.38	2.50	0.63	1611375	
SER 0500 F16	3/8	0.50	3.25	0.63	9990500	
SER 0625 H 16	3/8	0.63	4.00	0.63	9910625	
SER 0750 K16	3/8	0.75	5.00	0.75	2410750	
SER 1000 M16	3/8	1.00	6.00	1.00	2411000	
SER 1250 P16	3/8	1.25	7.00	1.25	2411250	
SER 1000 M22	1/2	1.00	6.00	1.00	3211000	
SER 1250 P22	1/2	1.25	7.00	1.25	3211250	
SER 1500 R22	1/2	1.50	8.00	1.50	3211500	
SER 1000 M27	5/8	1.00	6.00	1.25	4011000	
SER 1250 P27	5/8	1.25	7.00	1.25	4011250	
SER 1500 R27	5/8	1.50	8.00	1.50	4011500	

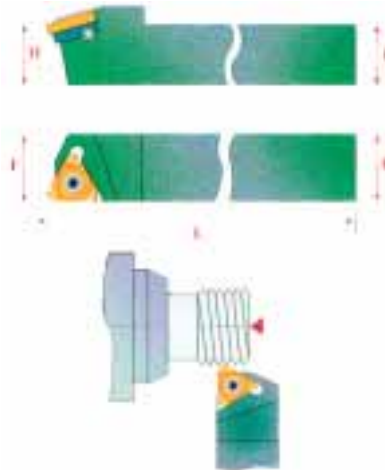

Standard Type

*Toolholders without anvil

INTERNAL TOOLHOLDERS, RIGHT HAND

LEFT HAND AND METRIC TOOLHOLDERS AVAILABLE; PLEASE INQUIRE

Model No.	Insert IC.	D Inch	Min Bore Dia.	L Inch	F Inch	Order No.	Price
*SIR 0205 H06	5/32	0.50	0.24	4.0	0.17	1020205	
*SIR 0265 K08	3/16	0.62	0.31	5.0	0.21	1220265	
*SIR 0375 H11	1/4	0.38	0.47	4.0	0.28	1620375	
*SIR 0375 K11	1/4	0.62	0.47	5.0	0.28	1621375	
*SIR 0500 L11	1/4	0.62	0.58	5.5	0.34	1620500	
*SIR 0500 M16	3/8	0.62	0.64	6.0	0.39	2420500	
*SIR 0625 P16	3/8	0.75	0.75	7.0	0.45	2420625	
SIR 0750 P16	3/8	0.75	0.90	7.0	0.51	2420750	
SIR 1000R16	3/8	1.00	1.16	8.0	0.65	2421000	
SIR 1250 S16	3/8	1.25	1.40	10	0.77	2421250	
SIR 1500 T16	3/8	1.50	1.65	12	0.90	2421500	
*SIR 0750 P22	1/2	0.75	0.90	7.0	0.59	3220750	
SIR 1000 R22	1/2	1.00	1.16	8.0	0.71	3221000	
SIR 1250 S22	1/2	1.25	1.50	10	0.85	3221250	
SIR 1500 T22	1/2	1.50	1.75	12	0.98	3221500	
SIR 1250 S27	5/8	1.25	1.56	10	0.88	4021250	
SIR 1500 T27	5/8	1.50	1.80	12	1.00	4021500	
SIR 2000 U27	5/8	2.00	2.30	14	1.25	4022000	
SIR 2500 V27	5/8	2.50	2.80	16	1.50	4022500	

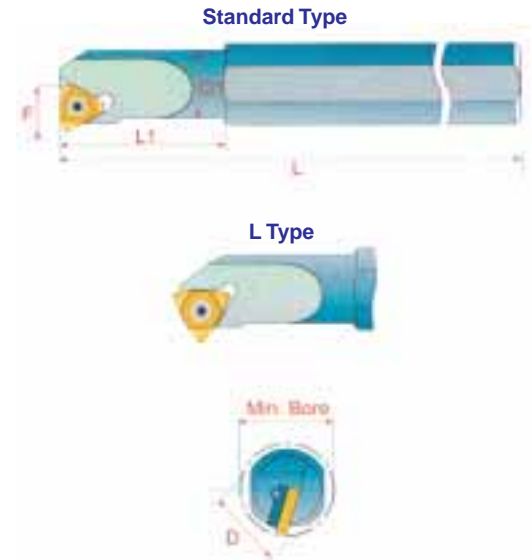

Standard Type

L Type

Min. Bore

* Toolholders without anvil

THREAD TURNING METHODS

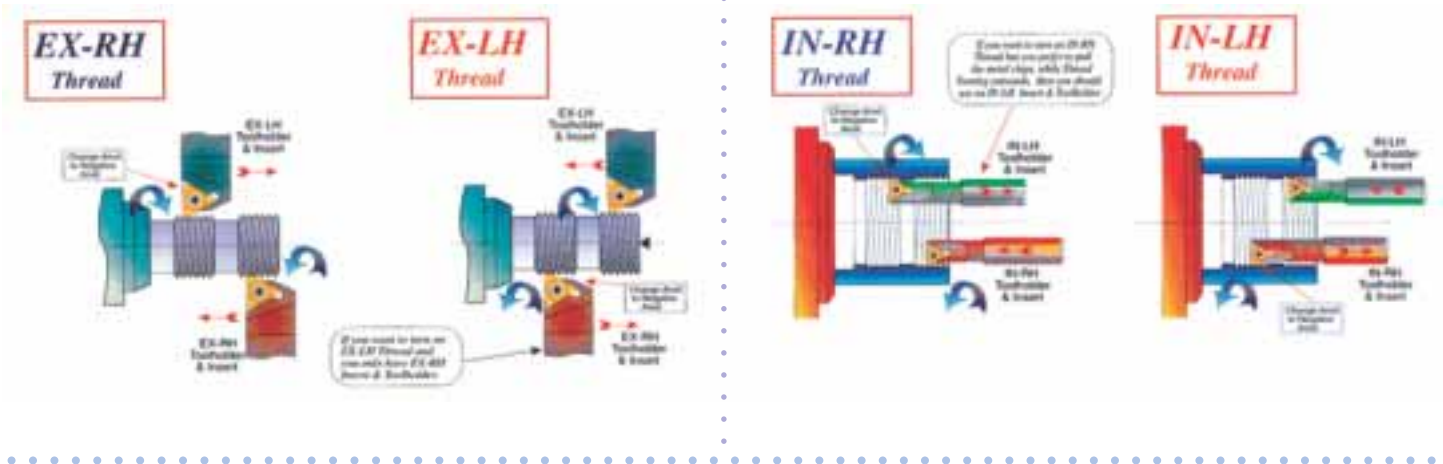

THREADING KITS

Threading Kits are a versatile solution for those who cut a variety of thread types in limited quantity and do not want to sacrifice thread quality. Kits Includes: 10 inserts, toolholder, screw, wrench and fitted case. Metric kits available; please inquire.



UN EXTERNAL KIT

MODEL NO. KEU
Order No. 3590001
Price:
Kit includes:

INSERTS

- 16 ER A60 P25C
- 16 ER G60 P25C
- 16 ER AG60 P25C
- 16 ER 8 UN P25C
- 16 ER 12 UN P25C
- 16 ER 14 UN P25C
- 16 ER 16 UN P25C
- 16 ER 18 UN P25C
- 16 ER 20 UN P25C
- 16 ER 24 UN P25C
- TOOLHOLDER SER 0750 K16

UN INTERNAL KIT

MODEL NO: KIU
Order No. 3590002
Price:
Kit includes:

INSERTS

- 16 IR A60 P25C
- 16 IR G60 P25C
- 16 IR AG60 P25C
- 16 IR 8 UN P25C
- 16 IR 12 UN P25C
- 16 IR 14 UN P25C
- 16 IR 16 UN P25C
- 16 IR 18 UN P25C
- 16 IR 20 UN P25C
- 16 IR 24 UN P25C
- TOOLHOLDER SIR 0750 P16

MINIATURE & ULTRA MINIATURE THREADING KITS

TYPE	Model No.	No. of Inserts	Inserts	Boring Bars	Order No.	Price
ULTRA	KU601-BXC	10	06 IR A60 BXC	SIR 0205 H06	3590102	
MINI	KM601-BXC	10	08 IR A60 BXC	SIR 0265 K08	3590202	

Other thread types available; please inquire

- Partial Profiles 55°
- Whitworth 55°
- NPTF
- BSPT
- Stub ACME and Coarse Thread ACME
- Trapez (DIN 103)
- Round (DIN 405)
- UNJ
- American Buttress
- Oil Thread

