

NB

NEW ITEM

SLIDE GUIDE

SEBS-B type

**Miniature Slide Guide Series with Retained Ball now
Offers Complete Selection**



Certificate No.958188



NIPPON BEARING CO., LTD.

Expanded Selection for Miniature Slide Guide Series

Full Selection Available for Retained Ball Type

Wide type of Miniature Slide Guide, providing greater allowable moment, is now available with retained ball structure. Due to this addition, full selection has been completed allowing for freedom of choice for the right component in your application.

STRUCTURE AND ADVANTAGES

NB's slide guide SEB type consists of a block and a guide rail, both of which have two precision ground raceway grooves. The block consists of a main body, balls, and return caps. This retained ball type has a retainer which prevents ball bearings from escaping when block is removed from rail.

Retained Balls

With the retained balls, the guide block may be removed from the rail without the balls falling out. This makes dis-assembly and re-assembly work easier.

All Stainless Steel Type (SEBS-BM/BYM Type)

All components are made of stainless steel. The return caps are now metallic and this increases usage versatility under special environments such as high temperature, clean room, or vacuum.

Compact Design

The two raceway and four-point contact structure of the SEB types minimize its height and give further advantage installation with limited space and reduces overall height.

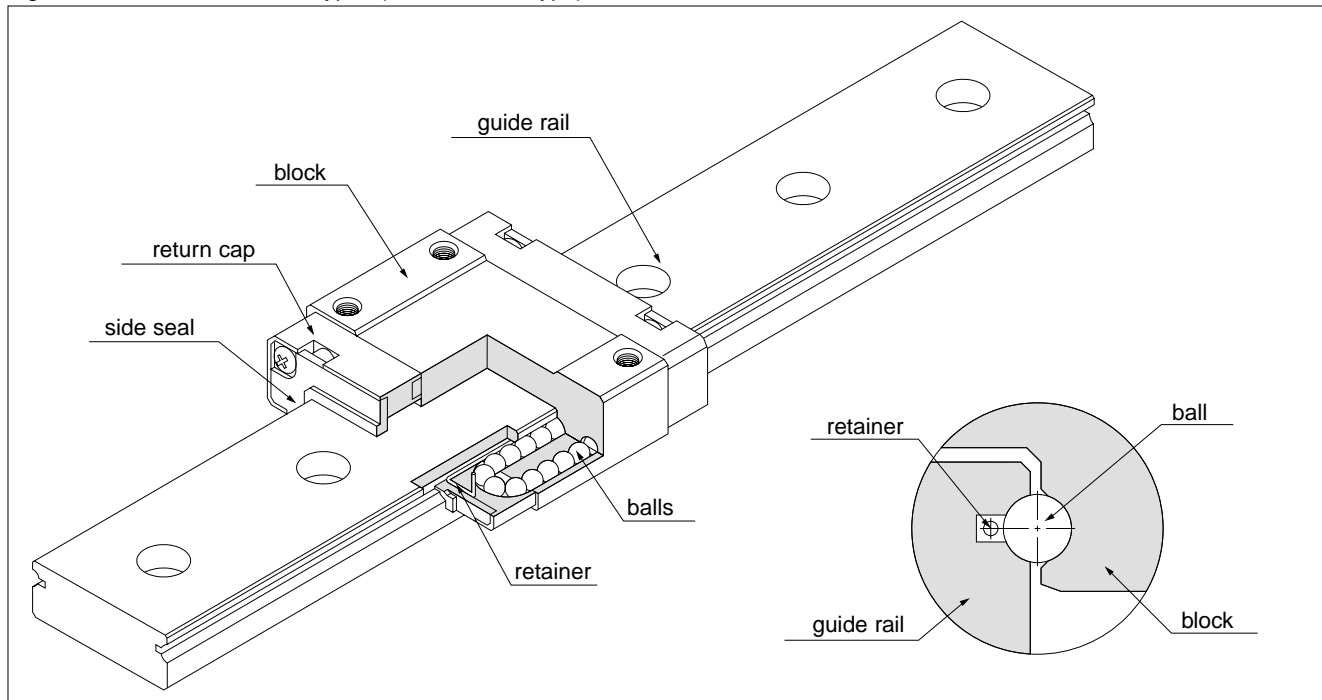
High Moment Loads

With the wide and long types an increase of moment capacity is realized. This permits for the use of "single" block designs possible.

Tapped-Hole Rail Types ("-N")

Slide guides with counter bore holes are standard and the tapped holes ("-N") are available upon request.

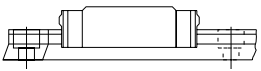
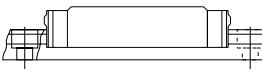
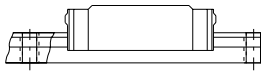
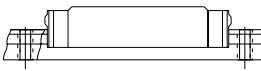
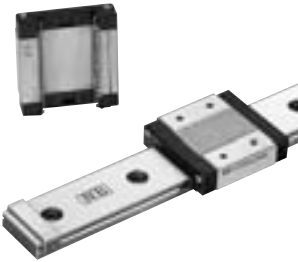



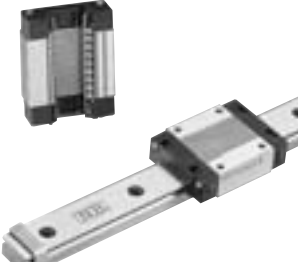
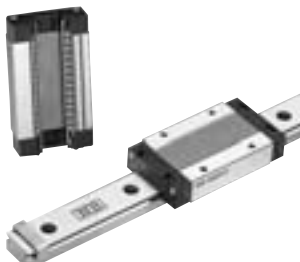
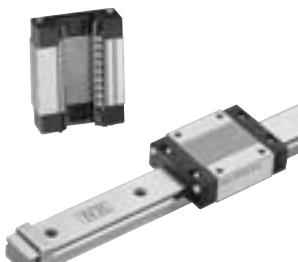

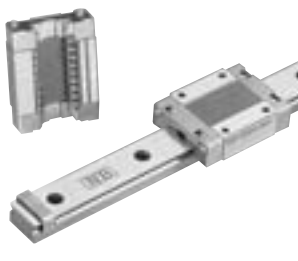
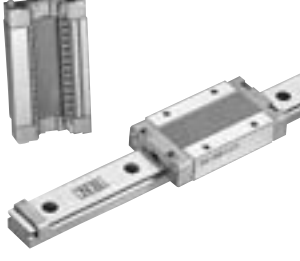
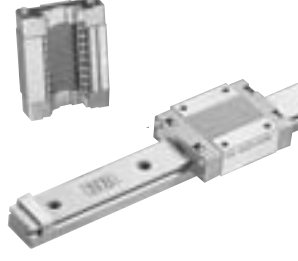
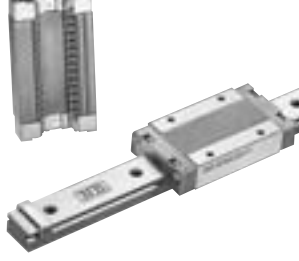
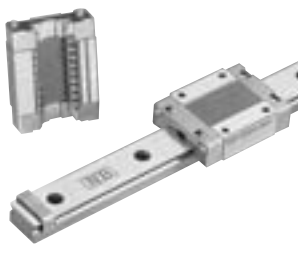
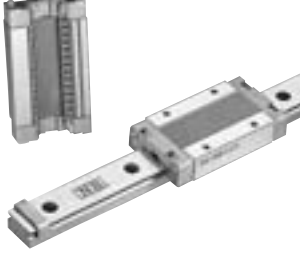
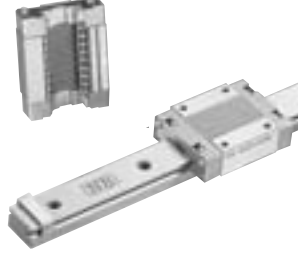
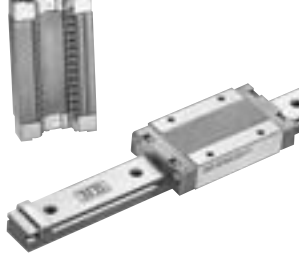
Figure 1 Structure of SEBS-B Types (Retained Ball Type)



TYPES

NB Miniature Slide Guide (SEB Type) series is categorized according to the width and length of block, the material of block and rail, the material of return cap and the rail installation method as shown in Table 1. Each type can be also offered with or without Side Seals.

Table 1 Types

		standard block standard rail (w/counter bore)	long type block standard rail (w/counter bore)	standard block N type rail (w/tapped hole)	long type block N type rail (w/tapped hole)
					
wide type (p.7)	regin return cap	SEBS-WB type NEW 	SEBS-WBY type NEW 	SEBS-WB-N type NEW 	SEBS-WBY-N type NEW 
	regin return cap	SEBS-B type 	SEBS-BY type 	SEBS-B-N type 	SEBS-BY-N type 
standard type (p.9)	regin return cap	SEBS-BM type 	SEBS-BYM type 	SEBS-BM-N type 	SEBS-BYM-N type 
	stainless return cap	SEBS-BM type 	SEBS-BYM type 	SEBS-BM-N type 	SEBS-BYM-N type 

ACCURACY

The SEB slide guides are available in two grades of accuracy: high-grade and precision-grade (P).

Table 2 Accuracy unit/mm

accuracy grade	high	precision
accuracy symbol	none	P
allowable dimensional difference in height H	± 0.020	± 0.010
paired difference for height H	0.015	0.007
allowable dimensional difference in width W	± 0.025	± 0.015
paired difference for width W	0.020	0.010
Running parallelism of surface C to surface A	Refer to Fig.2 & 3	
Running parallelism of surface D to surface B		

The difference of above pairs are applied to multiple number of blocks on the same rail. When the difference of height (H) of a pair on different rails is required, please indicate the number of rails in the part number. (Please refer to the "Part Number Structure" for further details.)

Figure 2 Accuracy

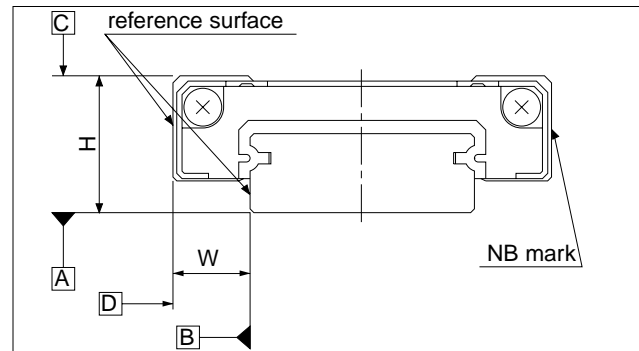
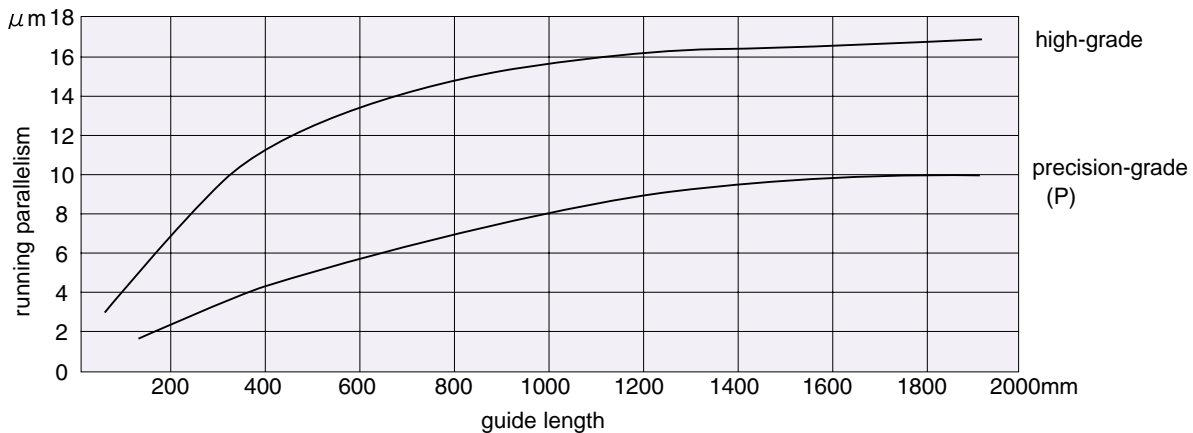


Figure 3 Motion Accuracy



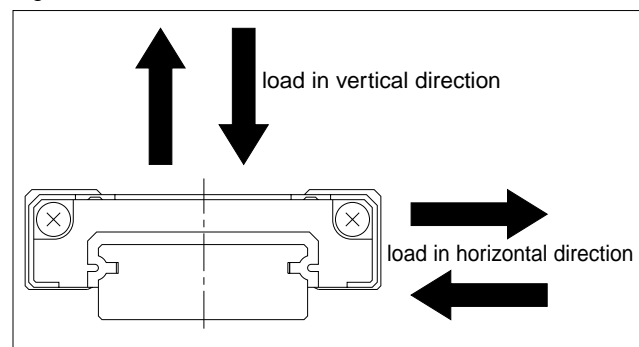
RATED LOAD

The load rating for SEB Type slide guides depends upon the direction of load.

Table 3 Load Rating

		retained ball types	standard types
basic dynamic load rating	vertical	$1.00 \times C$	$1.00 \times C$
	horizontal	$0.89 \times C$	$1.13 \times C$
basic static load rating	vertical	$1.00 \times Co$	$1.00 \times Co$
	horizontal	$0.84 \times Co$	$1.19 \times Co$

Figure 4 Direction of Load



PRE-LOAD

SEB slide guides are available with a standard pre-load (no suffix), light pre-load (T1), and a positive-clearance (T0).

Table 4 Pre-Load Symbol and Radial Clearance unit/ μm

size	type of pre-load and its symbol		
	clearance	standard	light
5W	T0 +1~+3	none -1~0	T1 -
7W	+3~+6	-3~0	-4~-2
9W			
12W	+4~+8	-3~0	-7~-3
15W			
5	+1~+3	-1~0	-
7	+3~+6	-3~0	-4~-2
9			
12	+4~+8	-3~0	-7~-3
15			
20			

Table 5 Operating Conditions and Pre-Load

pre-load	symbol	operating conditions
clearance	T0	Smooth movement is crucial. The installation tolerance is to be absorbed.
standard	none	Minute vibration is applied. High-precision movement is required. A moment in a given direction is applied.
light	T1	Light vibration is applied. A slight torque is applied. When moment is applied.

RAIL LENGTH

Slide guides with most commonly used lengths are available as standard. Unless otherwise specified, the distance to the first mounting hole (N) from one end of the rail will be located within the ranges listed in Table 6 for slide guides with non-standard lengths satisfying the following equation.

$$L = M \cdot P + 2N$$

L : length (mm) N : distance to the first hole from the end of the rail (mm)
M : number of pitches P : hole pitch (mm)

Figure 5 Rail

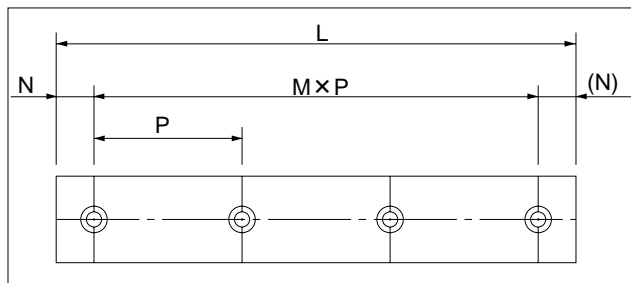


Table 6 Range of N dimension

unit/mm

size	N	
	more	less
5W	3	10
7W	4	19
9W		
12W	5	25
15W		
5	3	10.5
7		
9	4	14
12		16.5
15		24
20	6	36

INSTALLATION

Shapes of mounting planes

Slide Guides are generally mounted by pushing the reference surface of the rail and block against the shoulder of the mounting surface.

An escape groove should be provided at the corner of the shoulder in order to avoid interference with the corner of the rail or block.

Figure 6 Mounting Reference Surface Shapes-1

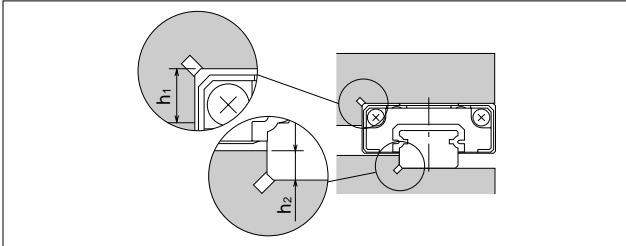


Figure 7 Mounting Reference Surface Shapes-2

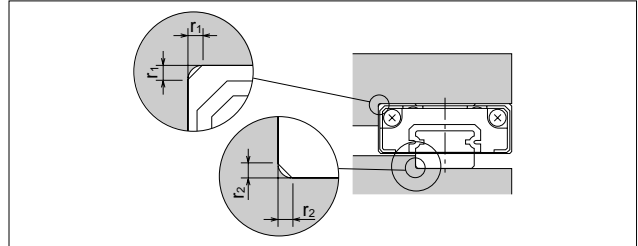


Table 7 Shoulder height of mounting unit:mm

part number	h_1	h_2
5W	2	1
7W	3	1.5
9W		2.5
12W	4	
15W		
5	2	1
7	2.5	
9	3	1.5
12	4	2
15	5	3.5
20		5

Table 8 Maximum corner radius unit:mm

part number	r_1	r_2
5W	0.3	0.3
7W		
9W		
12W		
15W	0.3	0.3
5		
7		
9		
12		
15		
20	0.5	0.5

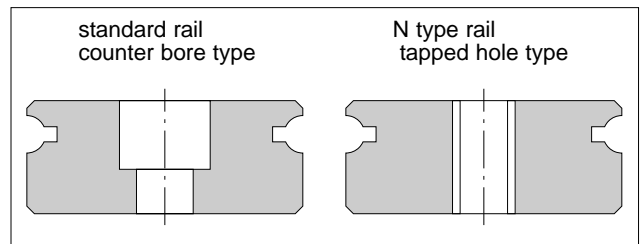
Recommended tightening torque

The bolts used to secure the rail should be tightened using a torque wrench. The recommended torque values are given in Table 9.

Table 9 Recommended Tightning Torque unit/N · m

size	standard rail		N type rail	
	bolt size	recommended torque	bolt size	recommended torque
5W	M2.6	0.6	M3	1.0
7W	M3	1.0	M4	2.3
9W				
12W	M4	2.3	M5	4.6
15W				
5	M2	0.3	M2.6	0.6
7			M3	1.0
9	M3	1.0	M4	2.3
12			M5	4.6
15			M6	10.0
20	M5	4.6	M6	10.0

Figure 8 Shapes of Rail



MOUNTING BOLTS

Small bolts for the SEB type are available from NB.

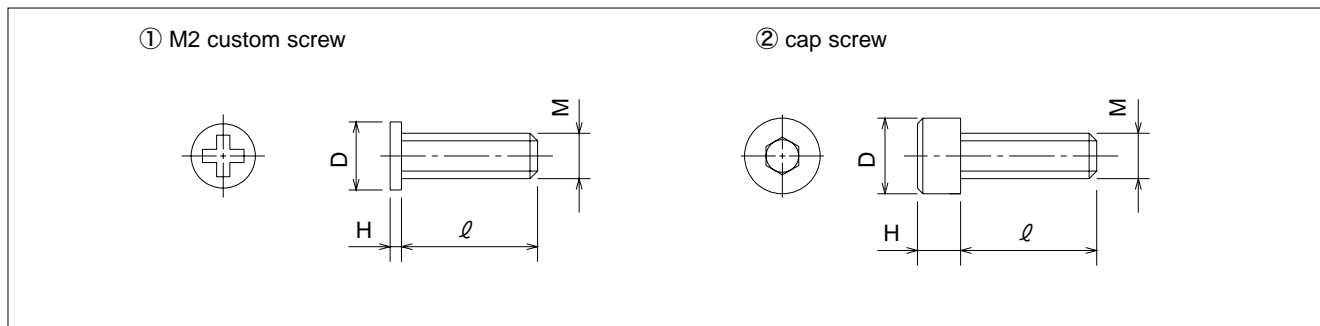
Table 10 Mounting Bolt (stainless steel)

unit/mm

type	type	bolt size	D mm	H mm	pitch mm	length ℓ mm
custom screw	fig.9- ①	M2	3	0.6	0.4	6
cap screw	fig.9- ②	M2	3.8	2	0.4	4,5,6,8,10
		M2.6	4.5	2.6	0.45	4,5,6,8,10

Custom screws for SEBS5A rails come with the rail.

Figure 9 Mounting Bolts (Sizes 5 & 7 only)



LUBRICATION

NB Slide Guides contain a quality lithium soap-based grease before they are shipped, and can be used as delivered. As use continues, lubricate them as required depending on operating conditions.

Under special use environments like clean room or vacuum, NB Slide Guides are available without grease or with special instructed grease applied upon request.

SEB Slide Guides retained ball type may be lubricated with ease as shown in Fig.10 (NB patented feature). NB offers two standard types of grease in syringe type applicators as shown in Table 11.



Figure 10 Greasing Method.

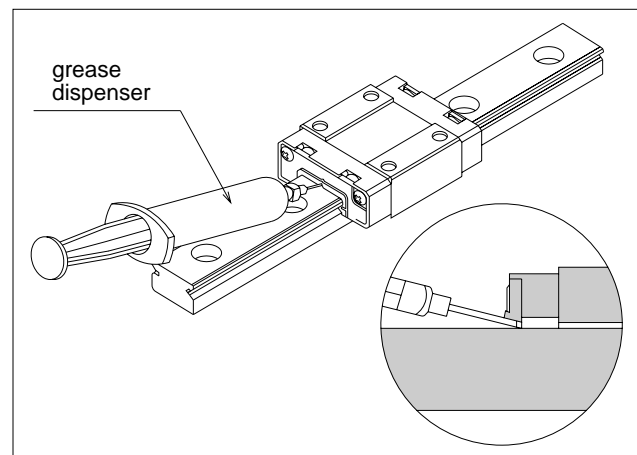


Table 11 Type of Grease

use	name of grease	contents
general	Multemp PS No.2 (Kyodo Yushi)	10g
low dust	K grease (NB)	10g

SEBS-WB/SEBS-WBY Type

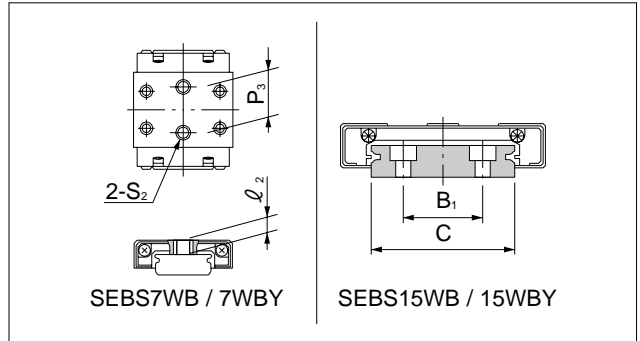


part number structure

example **SEBS 15WB Y UU 2 T1 -589 P N /W2**

SEBS: anticorrosion size	15WB: block size	Y: long	UU: seals on both ends	2: number of blocks attached to one rail	T1: light pre-load	-589: total length of rail	P: accuracy grade	N: rail mounting hole	W2: symbol for number of rails
--------------------------	------------------	---------	------------------------	--	--------------------	----------------------------	-------------------	-----------------------	--------------------------------

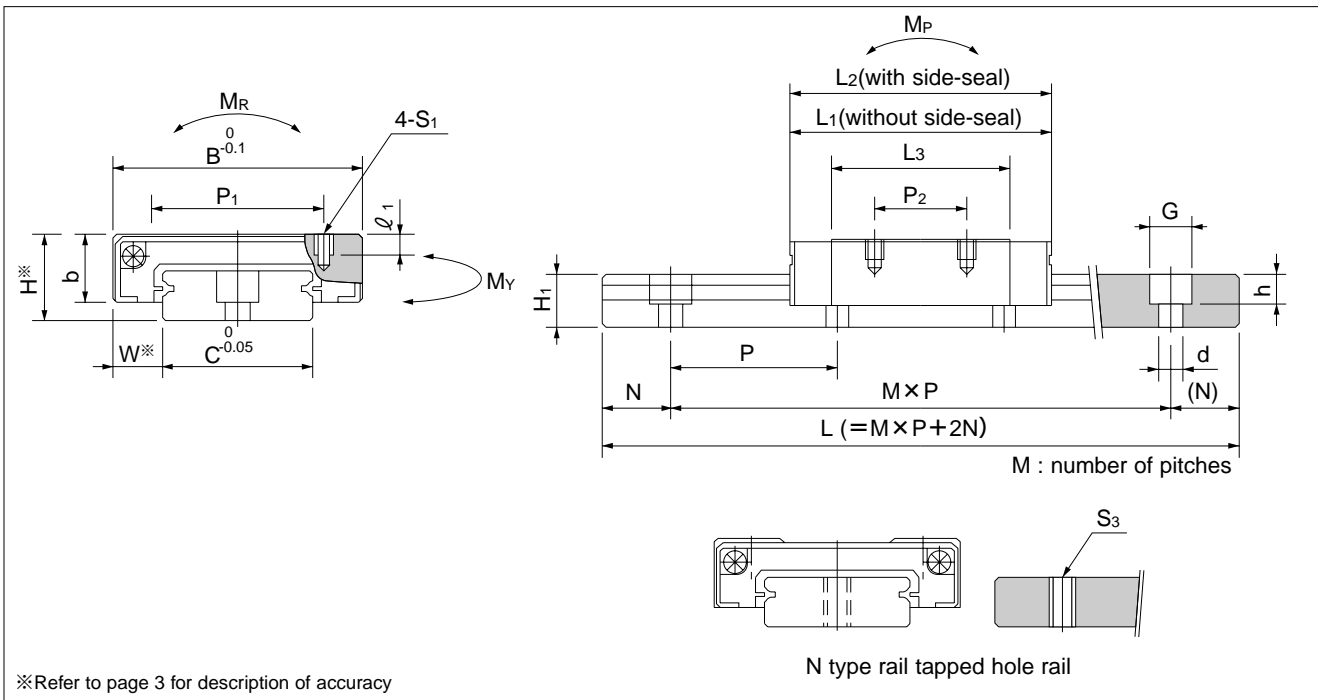
Note: The symbol for the number of rails does not mean the number of rails ordered.



part number	assembly dimensions		block dimensions												
	H	W	B	L ₁	L ₂	P ₁	P ₂	S ₁	∅ ₁	L ₃	P ₃	S ₂	l ₂	b	
	mm	mm	mm	mm	mm	mm	mm	mm	mm	mm	mm	mm	mm	mm	
SEBS 5WB	6.5	3.5	17	21.3	21.7	-	6.5	M3	2.3	14.3	-	-	-	5	
SEBS 5WB Y				27.3	27.7		11			20.3					
SEBS 7WB	9	5.5	25	31.4	31.4	19	10		2.8	20.2	12	M4	3.5	7	
SEBS 7WB Y				40.1	40.1		19			28.9	18				
SEBS 9WB	12	6	30	38.5	38.5	21	12		3	26.3	-	-	-	9	
SEBS 9WB Y				50.5	50.5		23			24					
SEBS 12WB	14	8	40	42.6	43	28	15		3.6	29	-	-	-	11	
SEBS 12WB Y				58.1	58.5		28			44.5					
SEBS 15WB	16	9	60	54.2	54.6	45	20		M4	4.5	38.8	-	-	-	13
SEBS 15WB Y				73.3	73.7		35				57.9				

part number	standard rail length										
	L										
	mm										
SEBS 5WB	50	70	90	110	130	150	170	190			
SEBS 7WB	50	80	110	140	170	200	230	260	290	350	410
SEBS 9WB	50	80	110	140	170	200	230	260	290	350	410
SEBS 12WB	70	110	150	190	230	270	310	350	390	430	470
SEBS 15WB	70	110	150	190	230	270	310	350	390	430	470

Contact NB for rail length exceeds the maximum standard length listed in the dimensional tables.



guide-rail dimensions							basic load rating		allowable static moment			mass		block size
H ₁	C	B ₁	d×G×h	S ₃	N	P	dynamic	static	M _P	M _Y	M _R	block	guide rail	
mm	mm	mm	mm		mm	mm	C kN	C ₀ kN	N·m	N·m	N·m	g	g/100mm	
4	10	—	3×5.5×3	M3	5	20	0.61	1.02	2.4	2.0	5.2	7	26	5WB
							0.88	1.47	4.9	4.1	7.4			5WB _Y
5.2	14	—	3.5×6×3.2	M4	10	30	1.59	2.57	9.1	7.7	18.3	20	51	7WB
							2.38	3.86	18.7	15.7	27.5			7WB _Y
7.5	18	—	3.5×6×4.5	M4	10	30	2.31	3.85	17.0	14.3	35.6	37	96	9WB
							3.38	5.63	36.2	30.4	52.1			9WB _Y
8	24	—	4.5×8×4.5	M5	15	40	3.02	5.04	24.7	20.7	61.7	71	137	12WB
							4.54	7.56	58.2	48.8	92.6			12WB _Y
9.5	42	23	4.5×8×4.5	M5	15	40	5.38	8.96	59.0	49.5	190.4	148	286	15WB
							8.07	13.45	131.4	110.3	285.7			15WB _Y

1kN ≒ 102kgf 1N·m ≒ 0.102kgf·m

470				
470	530			
550	630	710		
550	630	710	790	870

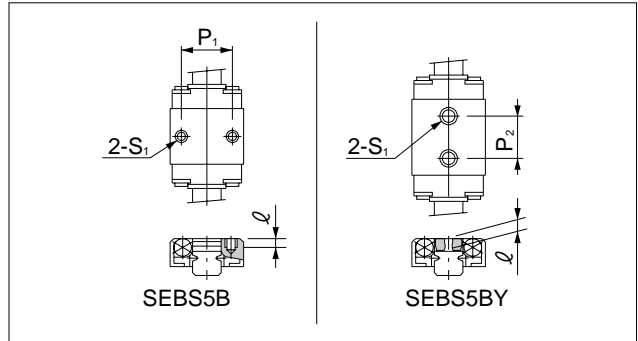
SEBS-B/SEBS-BY Type SEBS-BM/SEBS-BYM Type

part number structure

example **SEBS 15B Y M UU 2 T1 -589 P N /W2**

SEBS: anticorrosion	15B: block size	Y: return cap	M: seal	UU: number of blocks attached to one rail	2: total length of rail	T1: pre-load symbol	-589: accuracy grade	P: rail mounting hole	N: symbol for number of rails	W2: rail
blank	standard	blank	resin	blank	blank	blank	blank	blank	blank	blank
M	long	stainless steel	without seal	seals on both ends	blank	high	blank	counter-bored	single rail	double rails
						precision		flanged hole	triple rails	

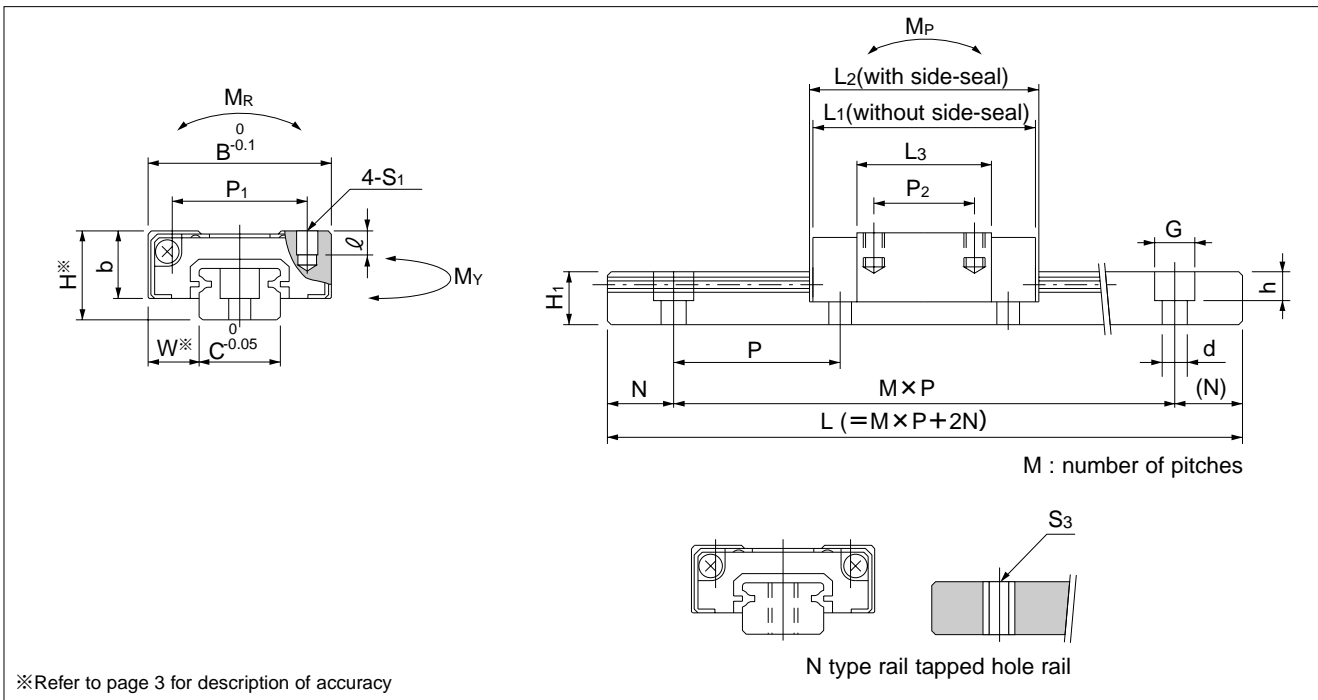
Note: The symbol for the number of rails does not mean the number of rails ordered.



part number		assembly dimensions		block dimensions									
		H	W	B	L ₁	L ₂	P ₁	P ₂	S ₁	ℓ	L ₃	b	
resin return cap	stainless return cap	mm	mm	mm	mm	mm	mm	mm		mm	mm	mm	
SEBS 5B	SEBS 5BM	6	3.5	12	16.3	16.7	8	—	M2	1.5	9.3	4.5	
SEBS 5BY	SEBS 5BYM				19.3	19.7	—	7	M2.6	1.8	12.3		
SEBS 7B	SEBS 7BM	8	5	17	23	23	12	8	M2	2.5	12.8	6.5	
SEBS 7BY	SEBS 7BYM				32.5	32.5		13			22.3		
SEBS 9B	SEBS 9BM	10	5.5	20	30.8	30.8	15	10	M3	3	19.6	7.8	
SEBS 9BY	SEBS 9BYM				40.3	40.3		16			29.1		
SEBS 12B	SEBS 12BM	13	7.5	27	33.8	34.2	20	15			3.5	20.2	10
SEBS 12BY	SEBS 12BYM				45.7	46.1		20				32.1	
SEBS 15B	SEBS 15BM	16	8.5	32	41.6	42	25	20	4	4	26.6	12	
SEBS 15BY	SEBS 15BYM				57.5	57.9		25			42.5		
SEBS 20B	SEBS 20BM	25	13	46	65.9	65.9	38	38	M4	6	44.7	17.5	
SEBS 20BY	SEBS 20BYM				85.7	85.7					6		64.5

part number	standard rail length										
	L										
	mm										
SEBS 5B	40	55	70	85	100	130	160				
SEBS 7B	40	55	70	85	100	130	160	190	220	250	280
SEBS 9B	55	75	95	115	135	155	175	195	235	275	315
SEBS 12B	70	95	120	145	170	195	220	245	270	295	320
SEBS 15B	70	110	150	190	230	270	310	350	390	430	470
SEBS 20B	220	280	340	400	460	520	580	640	760	880	1,000

Contact NB for rail length exceeds the maximum standard length listed in the dimensional tables.

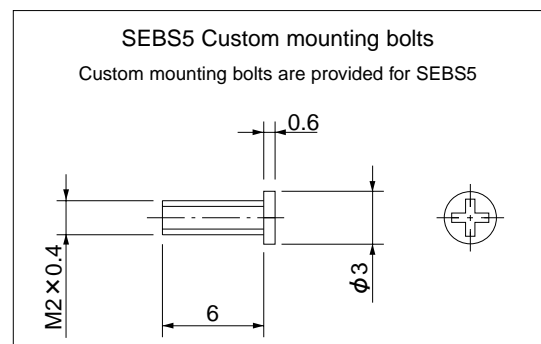


※Refer to page 3 for description of accuracy

guide-rail dimensions						basic load rating		allowable static moment			mass		size		
H ₁	C	d × G × h	S ₃	N	P	dynamic	static				block g				
mm	mm	mm		mm	mm	C	C ₀	M _P	M _Y	M _R	resin return cap	stainless return cap		guide-rail g/100mm	
4	5	2.4 × 3.5 × 0.8	M2.6	5	15	0.39	0.66	0.9	0.8	1.7	3	4	13	5B	
						0.52	0.88	1.7	1.4	2.2	4	5		5BY	
4.7	7	2.4 × 4.2 × 2.3	M3			1.10	1.70	3.5	3.0	6.2	9	12	21	7B	
						1.93	2.98	11.0	9.3	10.8	15	18		7BY	
5.5	9	3.5 × 6 × 3.5	M4	7.5	20	1.67	2.47	7.8	6.6	11.5	18	22	31	9B	
						2.47	3.70	17.6	14.9	17.2	27	31		9BY	
7.5	12	3.5 × 6 × 4.5		M4	10	25	2.55	3.70	11.7	9.9	23.1	35	44	59	12B
							4.15	6.02	31.0	26.3	37.6	53	62		12BY
9.5	15	3.5 × 6 × 4.5	M5	15	40	4.26	6.36	26.9	22.8	49.2	64	77	97	15B	
						6.92	10.3	71.1	60.2	80.1	98	110		15BY	
15	20	6 × 9.5 × 8.5	M6	20	60	8.91	12.7	92.7	78.5	130	228	266	205	20B	
						12.9	18.5	195	165	189	323	360		20BY	

1kN ≒ 102kgf 1N · m ≒ 0.102kgf · m

310						
355	395	435	475			
345	370	395	420	445	470	495
510	550	590	630	670		





NIPPON BEARING CO., LTD.

2833 Chiya, Ojiya-city, Niigata-pref., 947-8503 JAPAN
Phone:81-258-82-0011 Fax:81-258-81-1135

Local Sales Representative:

--

No.5550
First Edition:Jul.31,2003